

Mesh Specifications

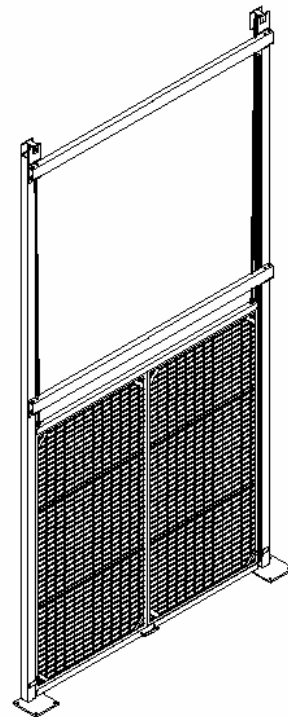
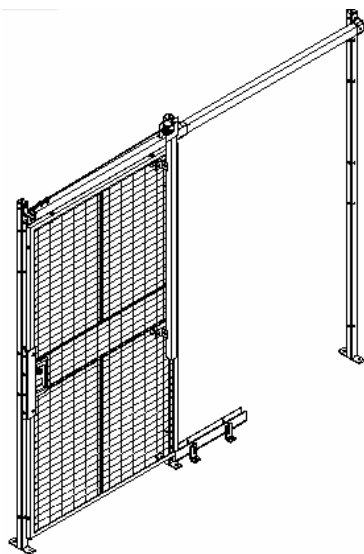
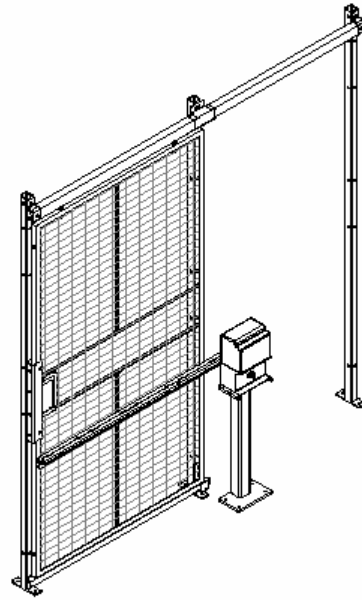
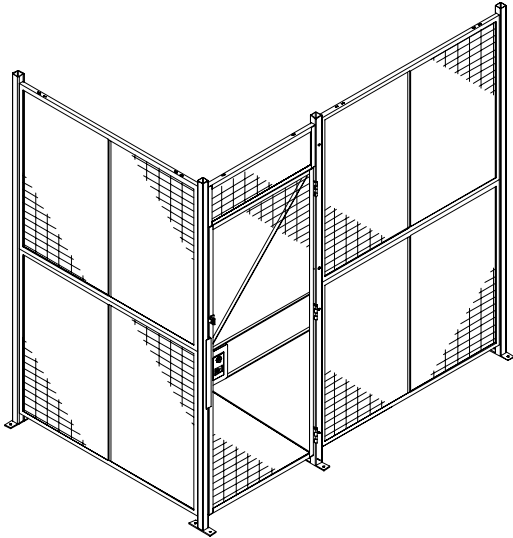

WireCrafters Style 840 Specifications 2" x 1" - #10 Gauge Woven Mesh

Mesh

Thickness: 10ga. (.135)

Design: 2 1/8" x 1 1/8" (center to center) rectangular woven wire (2"x1" actual opening)

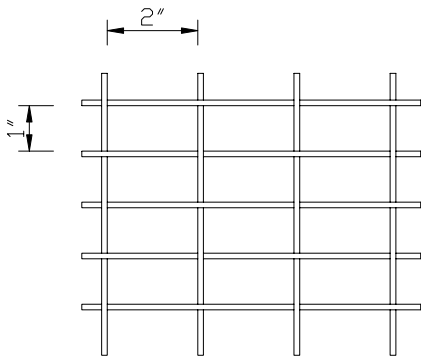

Panels

Frame: 1 1/4" x 1 1/4" x 1/8" Angle

Fabrication: Mesh is securely welded to frame with flat steel stiffeners welded to frame behind mesh panels longer than 3'6".

12'-0" w x 5'-0" h maximum size

Doors

Frame: 1 1/4" x 1 1/4" x 1/8" Angle

Fabrication: Mesh is securely welded to frame with flat steel stiffeners welded to frame for extra strength where needed.

Post

Material: 2" x 2" x #14ga. Square Tubing

Fabrication: 1/4" x 2" x 7" plate welded at base of post.

Hardware

Shall be 3/8" standard thread grade two plated for panel connections. Door hardware shall be 1/4" x 1" self drilling screws. 3/8" floor anchors and all other hardware furnished with each job.

Finish

Non-plated parts shall receive one prime coat of gray alkyd enamel electrostatically applied. Other colors are available for an up charge. Products are finished for interior applications. Materials are shipped loose and subject to nicks and scrapes while in transit.

WireCrafters Specifications #16 Gauge Sheet Metal

Mesh

Thickness: 16ga. (.060)

Design: #16gauge hot rolled sheet metal-solid panel (no opening)

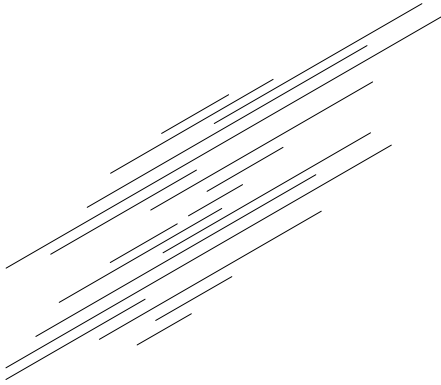

Panels

Frame: 1 1/4" x 1 1/4" x 1/8" Angle

Fabrication: Sheet Metal is securely welded to frame with flat steel stiffeners welded to frame behind Sheet metal panels longer than 3'6".

12'-0" w x 5'-0" h maximum size

Doors

Frame: 1 1/4" x 1 1/4" x 1/8" Angle

Fabrication: Sheet Metal is securely welded to frame with flat steel stiffeners welded to frame for extra strength where needed.

Post

Material: 2" x 2" x #14ga. Square Tubing

Fabrication: 1/4" x 2" x 7" plate welded at base of post.

Hardware

Shall be 3/8" standard thread grade two plated for panel connections. Door hardware shall be 1/4" x 1" self drilling screws. 3/8" floor anchors and all other hardware furnished with each job.

Finish

Non-plated parts are powder coat gray. Other colors are available for an up charge. Products are finished for interior applications. Materials are shipped loose and subject to nicks and scrapes while in transit.

WireCrafters Specifications

3/4" x 3/4" - #10 Gauge Woven Mesh

Mesh

Thickness: 10ga. (.135)

Design: 3/4" x 3/4" (center to center) square woven wire (5/8" actual opening)

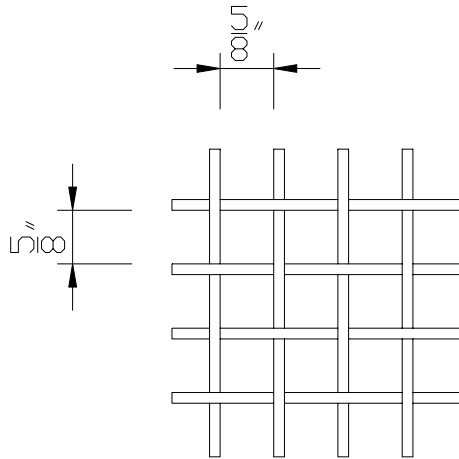

Panels

Frame: 1 1/4" x 1 1/4" x 1/8" Angle

Fabrication: Mesh is securely welded to frame with flat steel stiffeners welded to frame behind mesh panels longer than 3'-6".

10'-0" w x 4'-0" h maximum size

Doors

Frame: 1 1/4" x 1 1/4" x 1/8" Angle

Fabrication: Mesh is securely welded to frame with flat steel stiffeners welded to frame for extra strength where needed.

Post

Material: 2 x 2 x 14ga. Square Tubing

Fabrication: 1/4" x 2" x 7" plate welded at base of post.

Hardware

Shall be 3/8" standard thread grade two plated for panel connections. Door hardware shall be 1/4" x 1" self drilling screws. 3/8" floor anchors and all other hardware furnish with each job.

Finish

Non-plated parts are powder coat gray. Other colors are available for an up charge.

Product is finished for interior applications. Materials are shipped and subject to nicks and scrapes while in transit.

WireCrafters Specifications

3/8" x 3/8" - #12 Gauge Woven Mesh

"Two Mesh"

Mesh

Thickness: 12ga. (.105)

Design: 1/2" x 1/2" (center to center) square woven wire (3/8" actual opening)

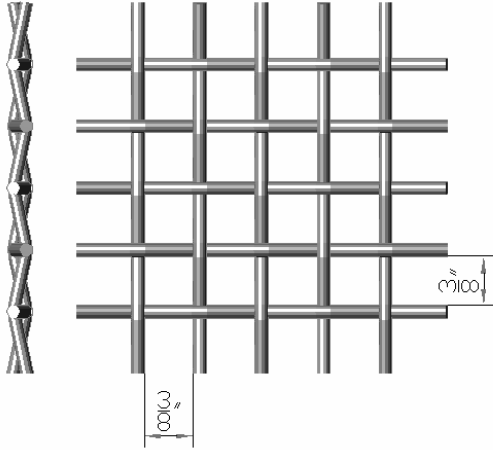

Panels

Frame: 1 1/4" x 1 1/4" x 1/8" Angle

Fabrication: Mesh is securely welded to frame with flat steel stiffeners welded to frame behind mesh panels longer than 3'-6".

10'-0" w x 4'-0" h maximum size

Doors

Frame: 1 1/4" x 1 1/4" x 1/8" Angle

Fabrication: Mesh is securely welded to frame with flat steel stiffeners welded to frame for extra strength where needed.

Post

Material: 2 x 2 x 14ga. Square Tubing

Fabrication: 1/4" x 2" x 7" plate welded at base of post.

Hardware

Shall be 3/8" standard thread grade two plated for panel connections. Door hardware shall be 1/4" x 1" self drilling screws. 3/8" floor anchors and all other hardware furnish with each job.

Finish

Non-plated parts are powder coat gray. Other colors are available for an up charge. Product is finished for interior applications. Materials are shipped and subject to nicks and scrapes while in transit.

WireCrafters Specifications 1 1/2" x 1 1/2" - #8 Gauge Woven Mesh

Mesh

Thickness: 8ga. (.162)

Design: 1 5/8" x 1 5/8" (center to center) square woven wire (1 1/2" actual opening)

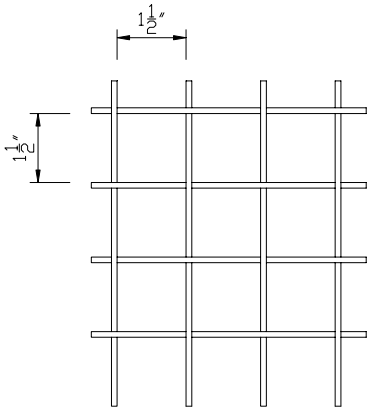

Panels

Frame: 1 1/4" x 1 1/4" x 1/8" Angle

Fabrication: Mesh is securely welded to frame with flat steel stiffeners welded to frame behind mesh panels longer than 3'6".

10'-0" w x 5'-0" h maximum size

Doors

Frame: 1 1/4" x 1 1/4" x 1/8" Angle

Fabrication: Mesh is securely welded to frame with flat steel stiffeners welded to frame for extra strength where needed.

Post

Material: 2" x 2" x #14ga. Square Tubing

Fabrication: 1/4" x 2" x 7" plate welded at base of post.

Hardware

Shall be 3/8" standard thread grade two plated for panel connections. Door hardware shall be 1/4" x 1" self drilling screws. 3/8" floor anchors and all other hardware furnished with each job.

Finish

Non-plated parts are powder coat gray. Other colors are available for an up charge. Products are finished for interior applications. Materials are shipped loose and subject to nicks and scrapes while in transit.

WireCrafters Specifications 2" x 2" - #6 Gauge Woven Mesh

Mesh

Thickness: 6ga. (.192)

Design: 2 1/4" x 2 1/4" (center to center) square woven wire (2" actual opening)

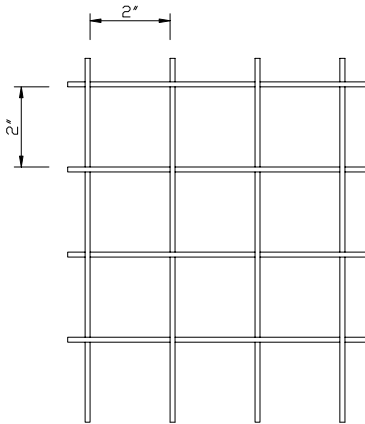

Panels

Frame: 1 1/2" x 1 1/2" x 1/8" Angle

Fabrication: Mesh is securely welded to frame with flat steel stiffeners welded to frame behind mesh panels longer than 3'6".

10'-0" w x 5'-0" h maximum size

Doors

Frame: 1 1/2" x 1 1/2" x 1/8" Angle

Fabrication: Mesh is securely welded to frame with flat steel stiffeners welded to frame for extra strength where needed.

Post

Material: 2" x 2" x #14ga. Square Tubing

Fabrication: 1/4" x 2" x 7" plate welded at base of post.

Hardware

Shall be 3/8" standard thread grade two plated for panel connections. Door hardware shall be 1/4" x 1" self drilling screws. 3/8" floor anchors and all other hardware furnished with each job.

Finish

Non-plated parts are powder coat gray. Other colors are available for an up charge. Products are finished for interior applications. Materials are shipped loose and subject to nicks and scrapes while in transit.

WireCrafters Specifications 2" x 2" - #10 Gauge Welded

Mesh

Thickness: 10 ga. (.135)

Design: 2" x 2" (center to center) square welded wire (1 7/8" actual opening)

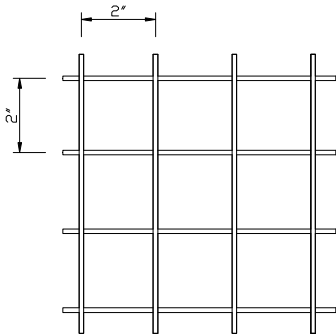

Panels

Frame: 1 1/4" x 1 1/4" -#13ga. roll formed angle.

Fabrication: Mesh is securely welded to frame with flat steel stiffeners welded to frame behind mesh panels longer than 3'6".

10'-0" w x 5'-0" h maximum size

Doors

Frame: 1 1/4" x 1 1/4" -#13ga. roll formed angle.

Fabrication: Mesh is securely welded to frame with flat steel stiffeners welded to frame for extra strength where needed.

Post

Material: 2" x 2" x #14ga. Square Tubing

Fabrication: 1/4" x 2" x 7" plate welded at base of post.

Hardware

Shall be 3/8" standard thread grade two plated for panel connections. Door hardware shall be 1/4" x 1" self drilling screws. 3/8" floor anchors and all other hardware furnished with each job.

Finish

Non-plated parts are powder coat gray. Other colors are available for an upcharge. Products are finished for interior applications. Materials are shipped loose and subject to nicks and scrapes while in transit.

WireCrafters Specifications 1 1/4" x 2 1/2" - #10 Gauge Welded

Mesh

Thickness: 10 ga. (.135)

Design: 1 1/4" x 2 1/2" (center to center) rectangular welded wire (1 1/8" x 2 3/8" actual opening)

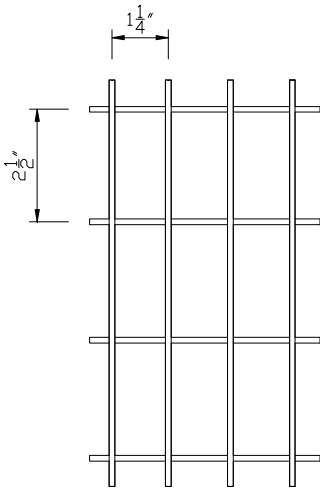

Panels

Frame: 1 1/4" x 1 1/4" -#13ga. roll formed angle

Fabrication: Mesh is securely welded to frame with flat steel stiffeners welded to frame behind mesh panels longer than 3'6".

10'-0" w x 5'-0" h maximum size

Doors

Frame: 1 1/4" x 1 1/4" -#13ga. roll formed angle.

Fabrication: Mesh is securely welded to frame with flat steel stiffeners welded to frame for extra strength where needed.

Post

Material: 2" x 2" x #14ga. Square Tubing

Fabrication: 1/4" x 2" x 7" plate welded at base of post.

Hardware

Shall be 3/8" standard thread grade two plated for panel connections. Door hardware shall be 1/4" x 1" self drilling screws. 3/8" floor anchors and all other hardware furnished with each job.

Finish

Non-plated parts are powder coat gray. Other colors are available for an upcharge. Products are finished for interior applications. Materials are shipped loose and subject to nicks and scrapes while in transit.