

WireCrafters

Installation Instructions

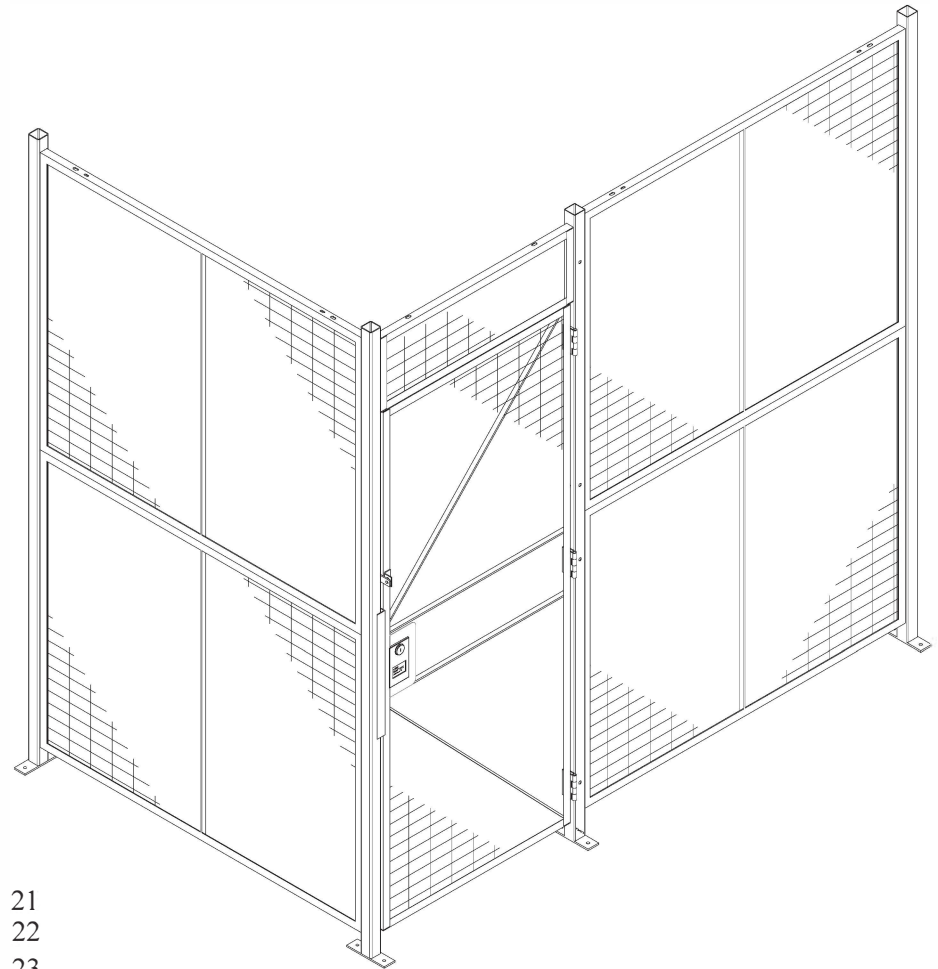

INCLUDED IN THIS MANUAL

General Information	2	Slide Door Padlock Lug	21
Panels & Posts	3-4	Track Stop	22
Adjustable panels	5	Tunnel Door	23
TES-4 & JSPE Detail	6-7	Basic Ceiling	24
Hinge Door Hardware	8	2" x 2" Horizontal Ceiling Tube	25
Hinge Door Inside Swing	9	2" x 4" Horizontal Ceiling Tube	26
Hinge Door Outside Swing	10	2" x 6" Horizontal Ceiling Tube	27
Door Lock Hole Cover Plate	11	Ceiling Tube Masonry Connections	28
Dutch Door	12	2" x 2" Intermediate/Spacer Tube	29
Double Hinge Door	13	Physical Barrier	30
Slide Door Hardware	14	Barrier Hinge Door Outside Swing	31
Slide Door Outside	15 - 16	Barrier Hinge Door Inside Swing	32
Slide Door Inside	17 - 18	Physical Barrier Magnet Latch	33
Slide Door Panel Assembly	19	Rack Back®	34
Slide Door Receiver	20	Rack Back® Hinge Door	35
		Component Location Work Sheet	36

We're Here To Help
1-800-626-1816
Mon-Fri 8am-5pm ET

WireCrafters, LLC.

6208 Strawberry Lane
Louisville, Kentucky 40214

502/363-6691
502/361-3857 FAX

General Information

www.wirecrafters.com
1-800-626-1816

The following General Installation Instructions should be used as a guide for installing WireCrafters Style 840 Partitions. Because of the varying job site conditions, and infinite layout possibilities, there is no “recommended” way to install the product. Good common sense and proper safety precautions must be used during installation. The product may be unstable during installation; proper temporary bracing should be used until all hardware is tightened and the product is properly anchored to the floor. Permanent field bracing may be installed at installer’s/owner’s discretion. Install problems arising from job site conditions should be referred to a professional installer. Refer product assembly questions to WireCrafters.

TOOLS RECOMMENDED

Chalk line & marker	Drill with adjustable clutch and 3/8” nut driver	(2) Step ladders if installing ceiling
Tape Measure	Hammer Drill with 3/8” masonry bit	(2) C clamps or Vise-Grip® type clamps
Level	(2) 9/16” open end wrenches and/or	#1 & #2 Phillips Screw Driver
Hacksaw	(2) 9/16” deep socket ratchets	1/2” deep socket or 1/2” open end wrench

SELF DRILLING SCREW INSTALLATION RECOMMENDATIONS

When installing self drilling screws use a standard variable speed screw gun equipped with an adjustable clutch or depth locating nose piece. Take care not to over tighten or strip, set drill accordingly. **DO NOT USE IMPACT TYPE GUN WHEN INSTALLING SELF DRILLING SCREWS.** Securely clamp component parts in place before attaching with self drilling screws.

INSTALLER TIPS

1. Installation is best accomplished with a two or three person crew.
2. Before starting, review all installation instructions pertinent to your layout (i.e. panels, doors, etc.)
3. “Face Side” of the partition is the outside, where nuts and bolts will NOT be visible or accessible. “Inside” of the partition has one leg of the panel frame pointing in. Assembly hardware will be on the inside of most layouts.
4. Panels install horizontally between posts, 2” mesh opening should be parallel with floor.
5. Identify all panels by part number. If possible stage parts where they will be installed.
6. Special size panels have metal tags on the mesh and are referenced on drawing.
7. Make sure all posts are installed plumb (vertically perpendicular to floor). Shims (not provided) may be necessary.
8. Use a 3-1/4” spacer block (not provided) to support far end of panel during setup.
9. Begin installation process at a building wall, end or corner of layout.
10. Gauge hinge door opening by width of transom panel.
11. Gauge slide door opening by door width (e.g. 48” between posts for 4’ wide slide door). When necessary, slide door openings may be narrowed to adjust length of adjacent run.
12. Standard hinge, double hinge, and slide doors are universal and may be installed inside or outside swing, left or right hand. Dutch and special doors are not universal and must be installed as shown out on drawing.
13. Installer should cut off any bolts or hardware protruding into aisle ways or around door openings.
14. Installer should touch up all nicks, marks, and scratches with touch up paint provided.

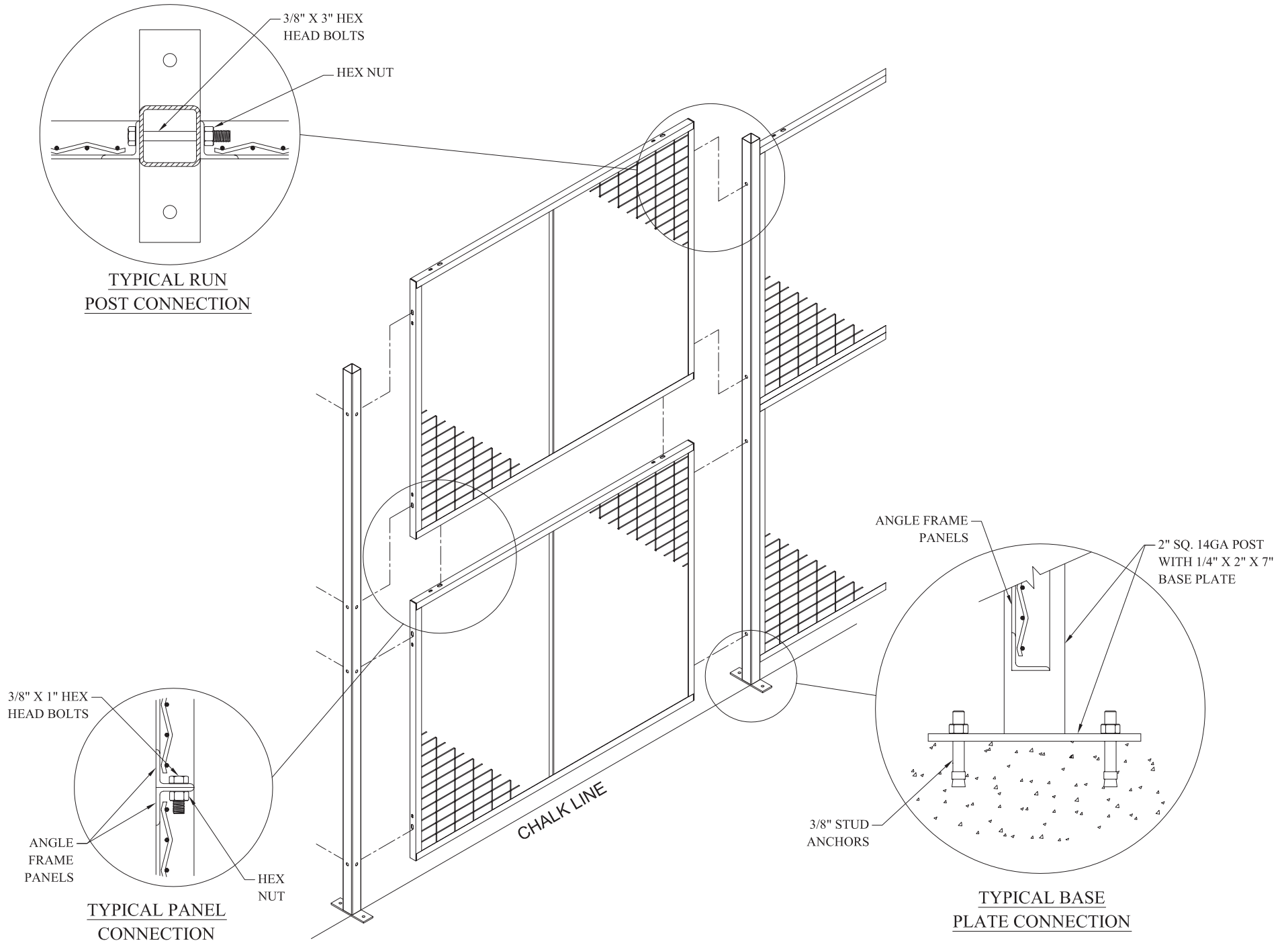

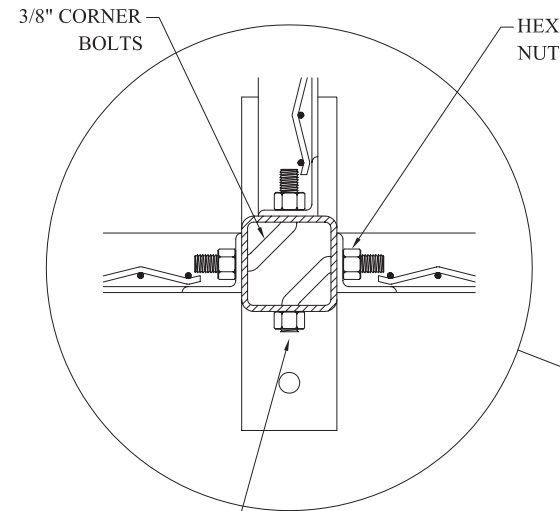

INSTALLER NOTE
HACK SAW
AND DE-BURR ALL
PROTRUDING THREADS

TYPICAL TEE
POST CONNECTION

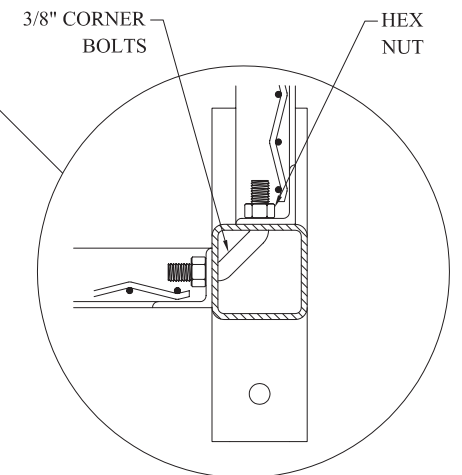
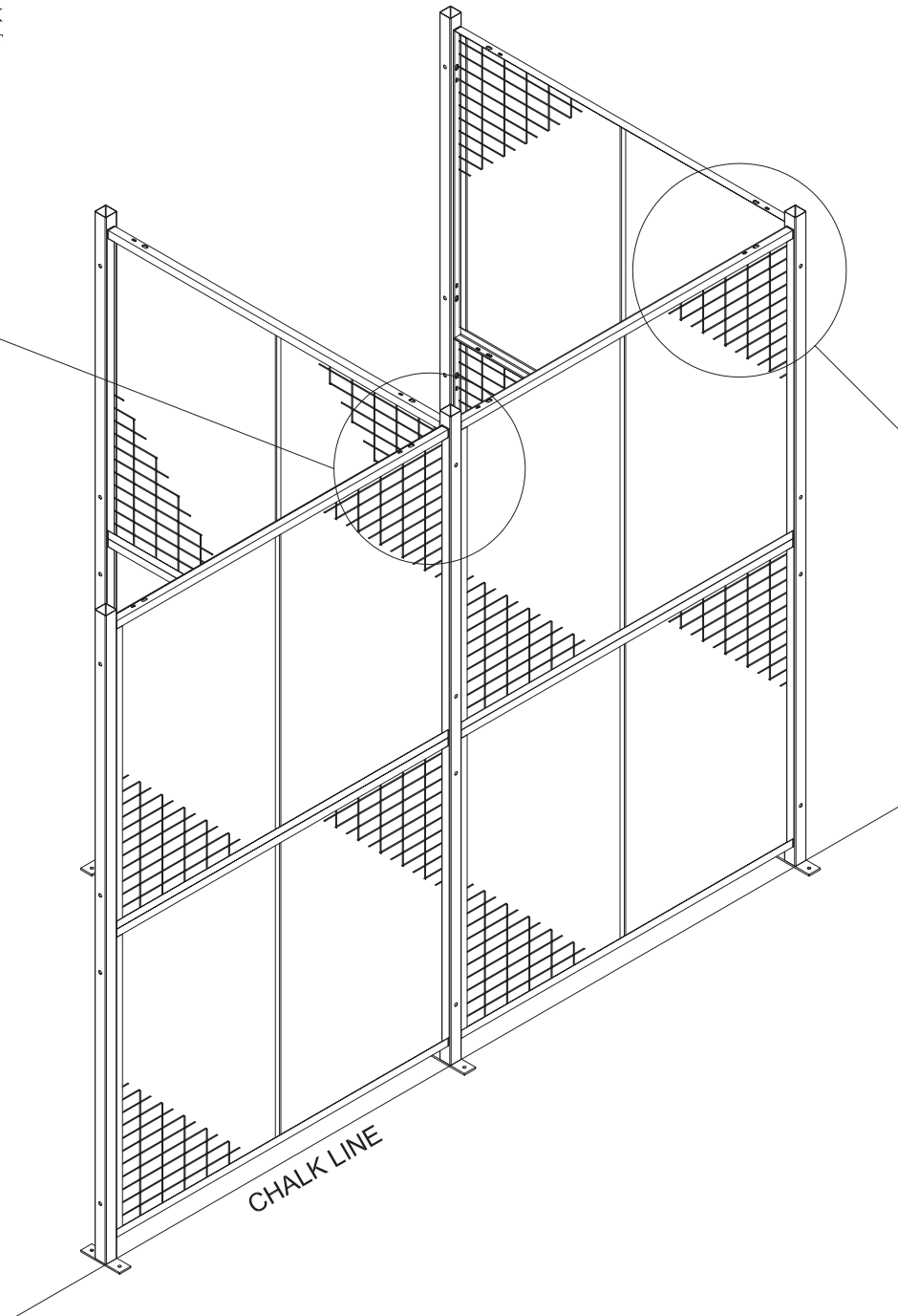

TYPICAL CORNER
POST CONNECTION

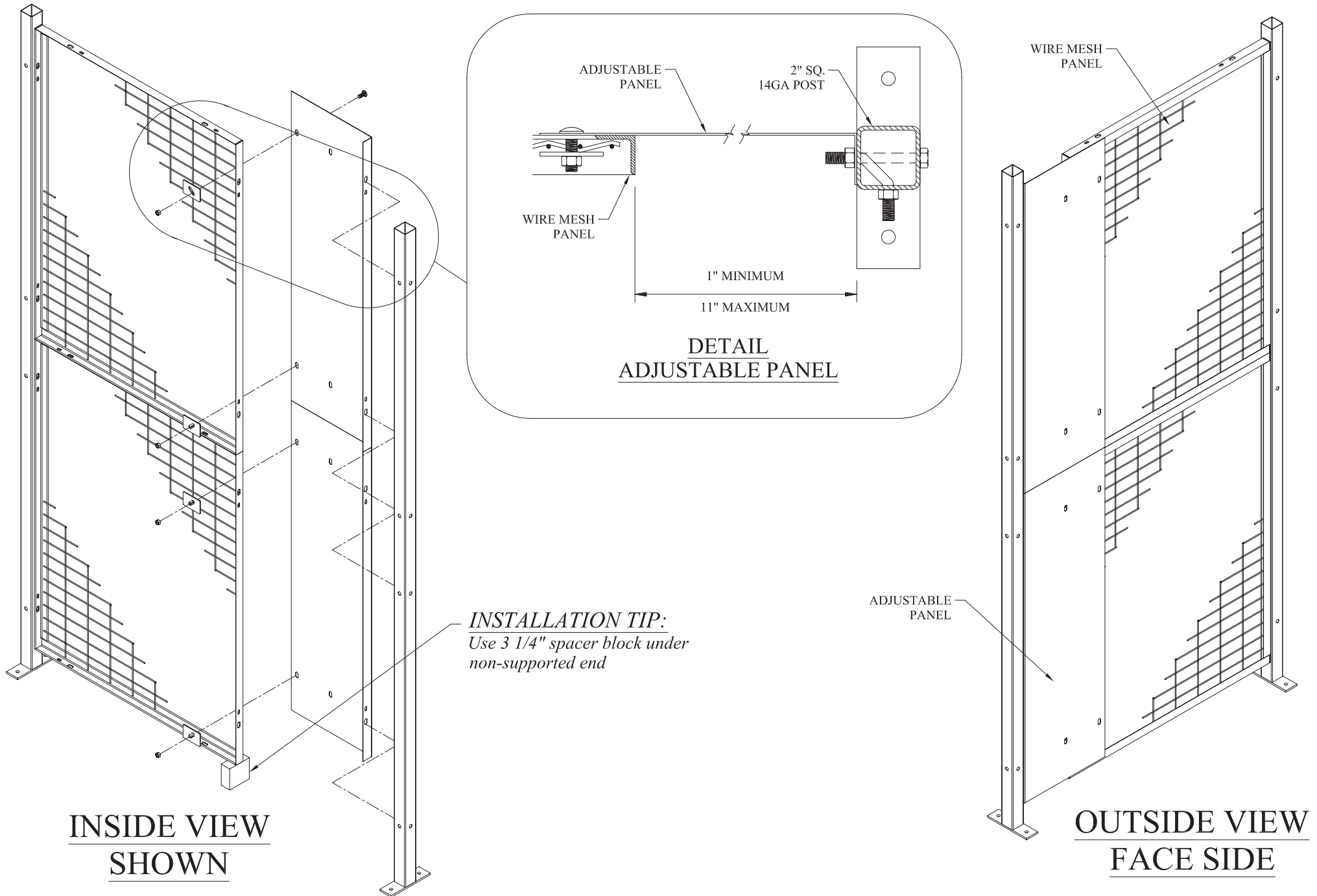

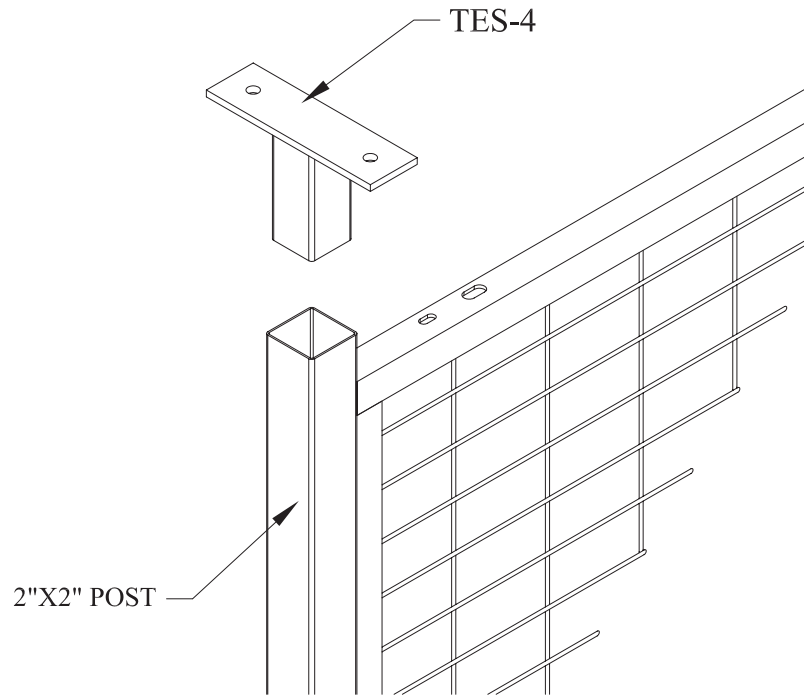

STEP#1

Insert TES-4 into top of post.

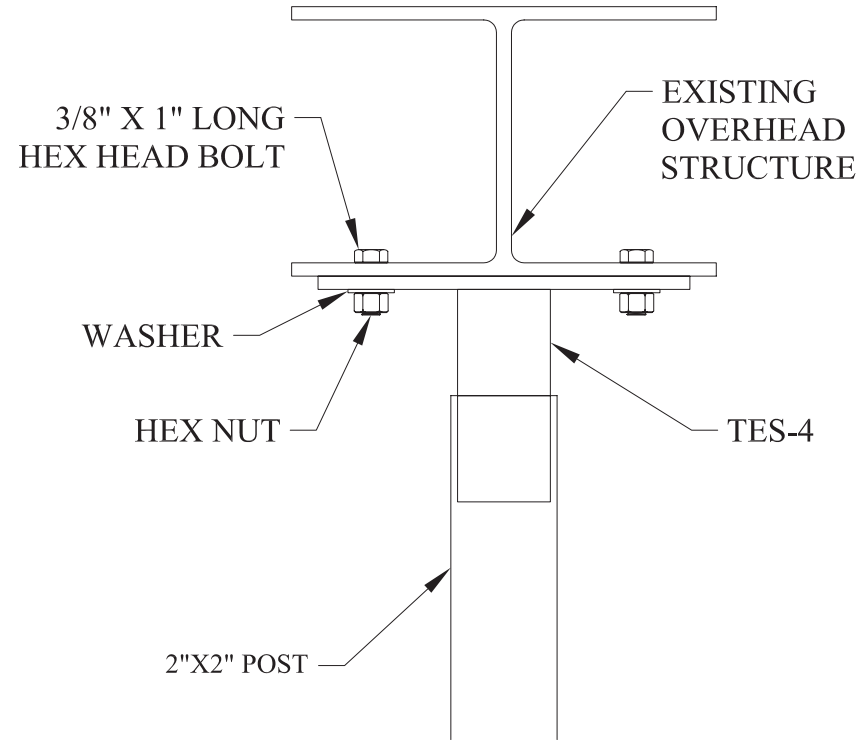

STEP#2

Anchor TES-4 into overhead structure using 3/8" hardware provided. If TES-4 cannot be connected with supplied hardware, installer will have to provide hardware to attach.

TES-4

Accessory item used to anchor partition wall to overhead structure.

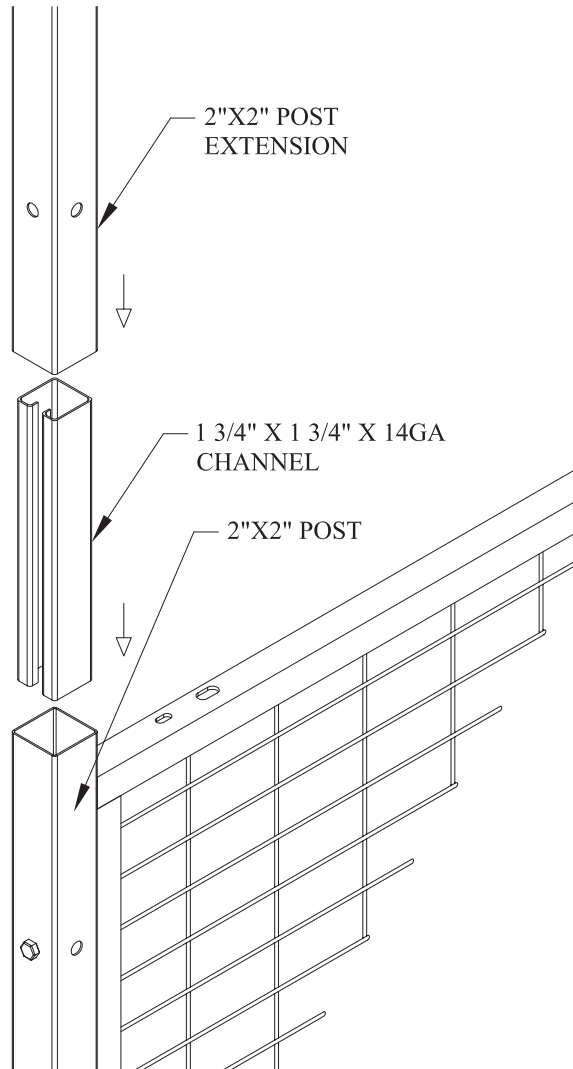

STEP#1

Force the JSPE into the bottom post until it is bottom out on panel bolt.

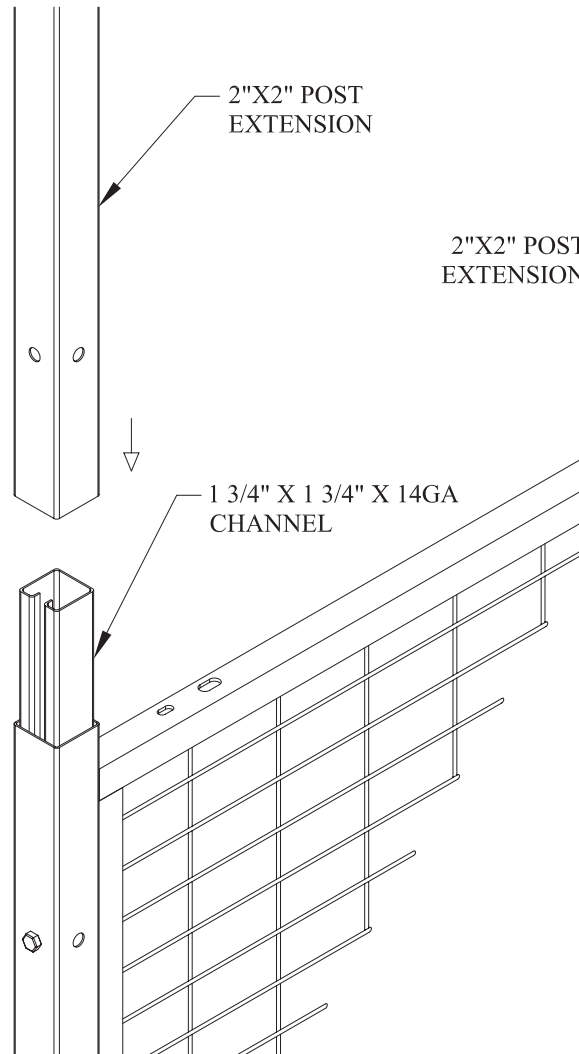

STEP#2

Force post extension over JSPE.

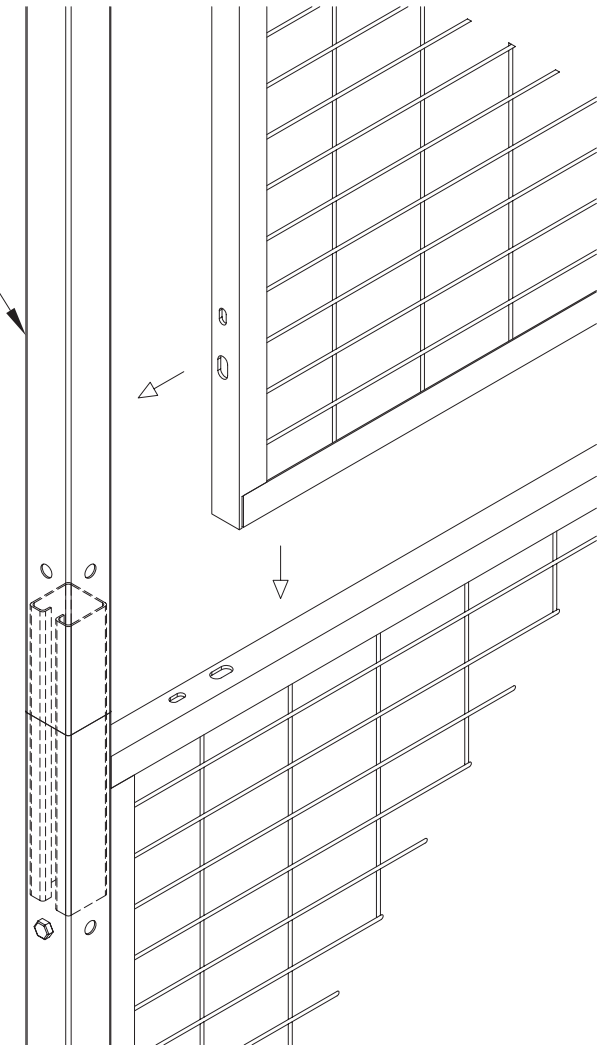

STEP#3

Force extension until flush with bottom post.

JSPE

Accessory item used to extend height of existing wall.

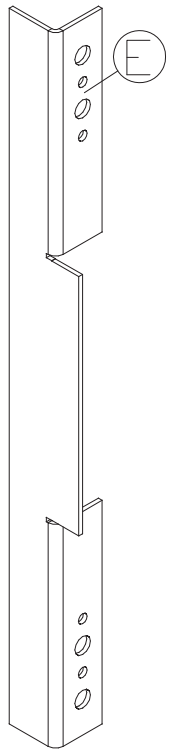

Hinge Door Flat Padlock Lug
Quantity (1)
Part# HDLPLLI

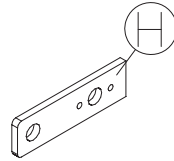

Hinge Door Lock Receiver
Quantity (1)
Part# HDLRLI

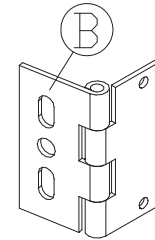
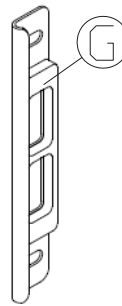

Door Hinge
Quantity (3)
Part# HDHG44IPL

Note:
Do not use Door Hinges and Hinge Door Lock Receiver shown on this page if Electric Strike is used. Refer to Surface Mount Electric Mount manual for hinges.

SEE SUPPLIED LOCK MANUFACTURER INSTRUCTIONS FOR ASSEMBLY

Hinge Door Angle Pick Plate
Quantity (1)
Part# HDCPLI

- HDFSPK - Fastener Pack (Contents Below)
- (25) FSHOPG- Gray Hole Plugs
 - (8) COBO- 3/8" Corner Bolts
 - (8) FS383- 3/8" x 3" Hex Head Cap Screw
 - (6) FS381- 3/8" x 1" Hex Head Cap Screw
 - (30) FS38N- 3/8" Hex Nut
 - (4) FS38STA- 3/8" Wedge Anchor
 - (1) FSTRNSPK- Self-Drilling Screws (25)

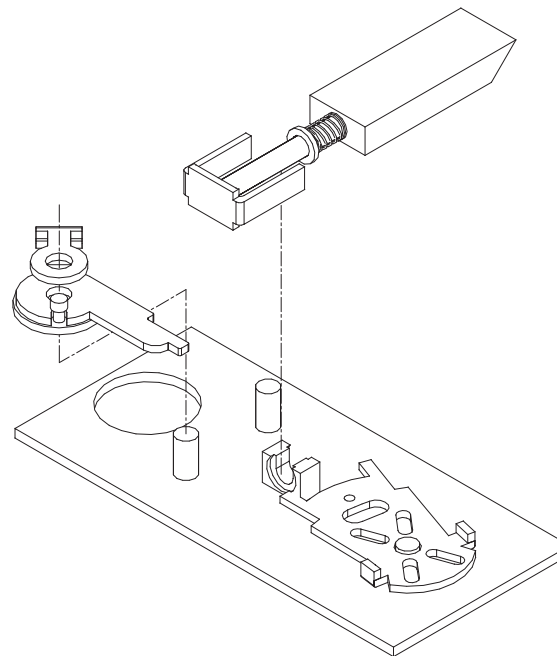

RIGHT HAND ASSEMBLY

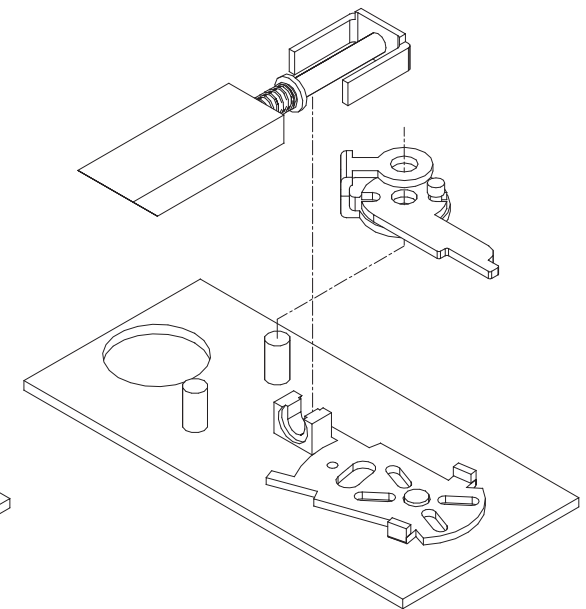

LEFT HAND ASSEMBLY

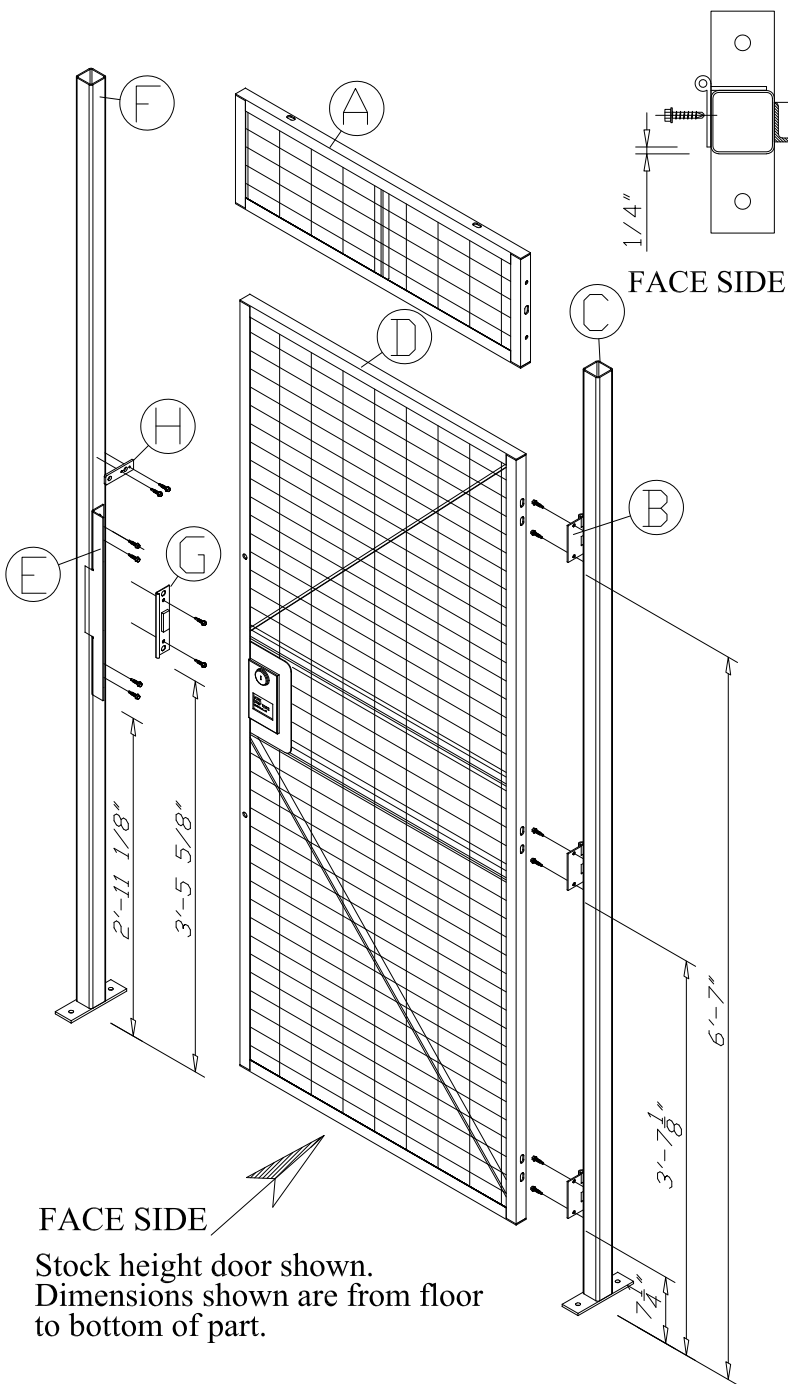

FACE SIDE

Stock height door shown.
Dimensions shown are from floor to bottom of part.

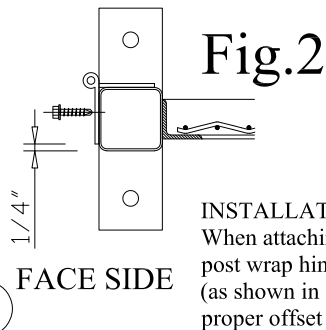

Fig. 2

INSTALLATION TIP:
When attaching hinge to door post wrap hinge around post (as shown in drawing) to set proper offset alignment

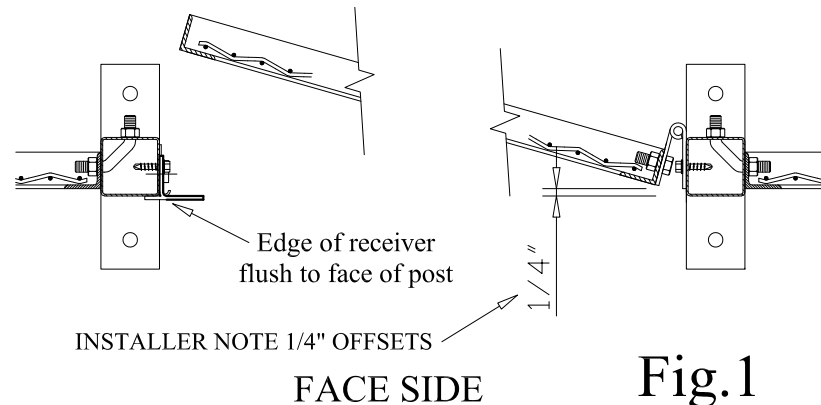

Fig. 1

INSTALLER NOTE 1/4" OFFSETS

FACE SIDE

Edge of receiver flush to face of post

INSTALLER NOTES:

1. Component parts attach using self-drilling screws. Use variable speed screw gun with adjustable clutch or depth locating nose piece. Use care not to over tighten and strip threads. **DO NOT USE IMPACT TYPE GUNS.** Securely clamp part in place before attaching with self drilling screws.
2. The dimensions shown on this page are from the floor to the bottom of the part for standard height 6' 11-3/4" door opening with 3-1/4" sweep space. Use worksheet on page 29 to calculate component locations for non-standard door opening heights or sweep spaces.
3. Partition wall should be set up and anchored to floor, with posts plumb, before attempting to install doors.

Hinge Door Inside Swing

1. Install transom panel (A) at top of door opening, check opening width at floor, and anchor posts to floor. Check that posts are plumb and opening is square.
2. Attach hinges (B) to door post (C) using two self drilling screws per hinge.
 - a. Note hinge placement offset detailed in Fig. 1 and install tip in Fig. 2.
 - b. If necessary, remove lower two 3/8" x 3" panel mounting bolts, and replace with corner bolts.
 - c. Stock Doors (3-1/4" sweep sp.), place bottom of hinge 7-1/4", 43 1/8", and 79" from floor.
 - d. Cut off and file smooth any protruding bolt threads.
3. Attach door panel (D) to hinges with two 3/8" x 1" bolts and nuts.
 - a. Set desired sweep space (3-1/4" for stock doors).
4. Attach pick plate (E) to door post (F) using four self drilling screws.
 - a. Note pick plate position offset detailed in Fig 1.
 - b. Bottom of pick plate installs 35-1/8" from floor for stock doors.
 - c. If necessary, remove two 3/8" x 3" panel mounting bolts and replace with corner bolts. Cut off and file smooth any protruding bolt threads.
5. Install cylinder lock (if applicable). See page 6.
6. Attach cylinder lock receiver (G) to door post (F) with two self-drilling screws.
 - a. Rolled side of receiver installs to face side of partition.
 - b. Bottom of receiver installs 41-5/8" from floor for stock doors.
7. Align padlock lug (H) with door padlock lug on door (D) and attach to post (F) with two self drilling screws. See page 11 for Bolt-On Angle Padlock Lugs.
8. Check operation of door, adjust as needed.

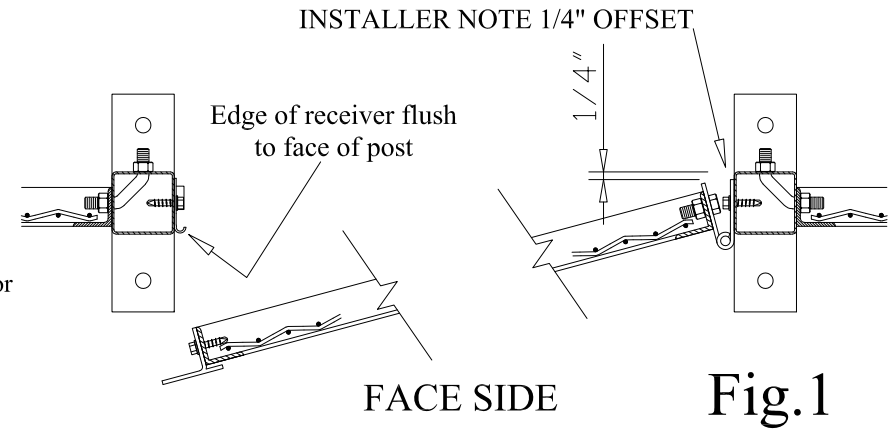
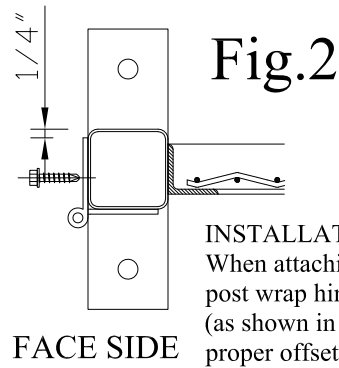
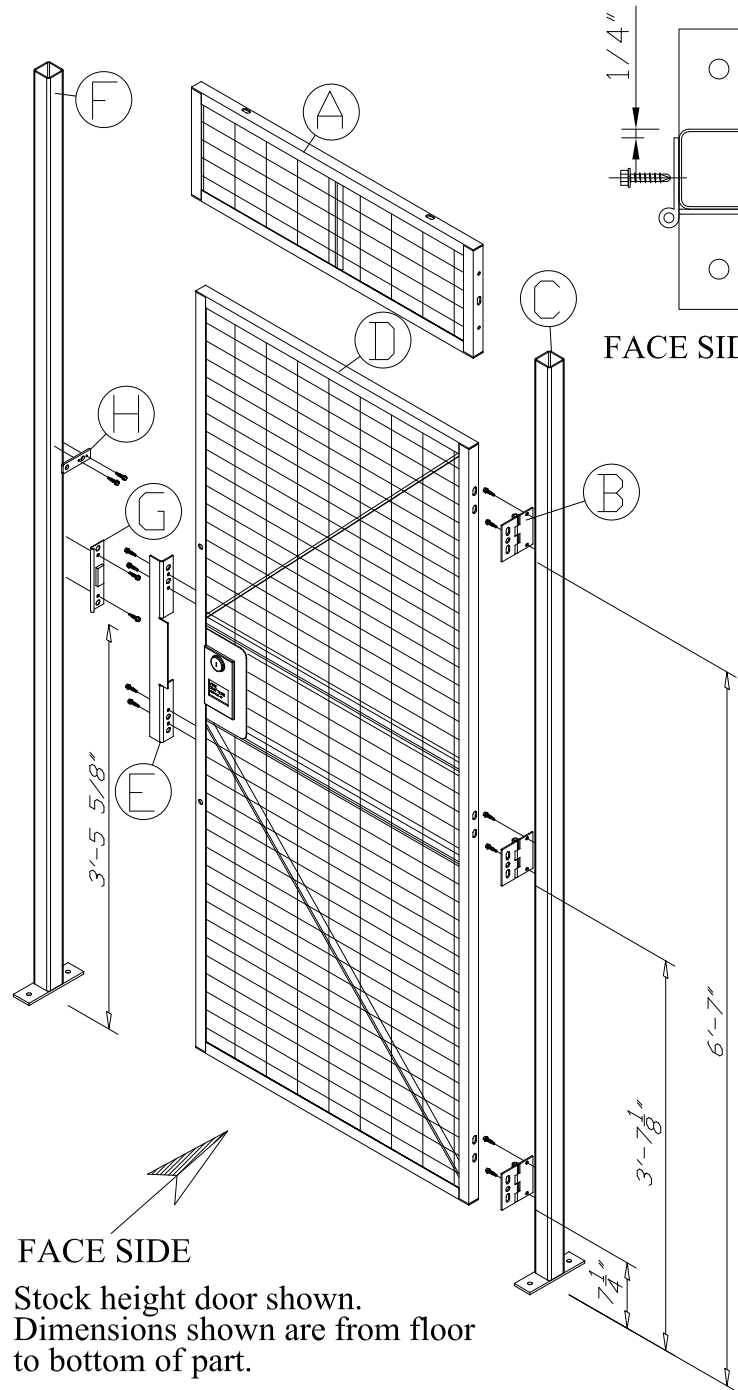

INSTALLER NOTES:

1. Component parts attach using self-drilling screws. Use variable speed screw gun with adjustable clutch or depth locating nose piece. Use care not to over tighten and strip threads. **DO NOT USE IMPACT TYPE GUNS.** Securely clamp part in place before attaching with self drilling screws.
2. The dimensions shown on this page are from the floor to the bottom of the part for standard height 6' 11-3/4" door opening with 3-1/4" sweep space. Use worksheet on page 29 to calculate component locations for non-standard door opening heights or sweep spaces.
3. Partition wall should be set up and anchored to floor, with posts plumb before attempting to install doors.

Hinge Door Outside Swing

1. Install transom panel (A) at top of door opening, check opening width at floor, and anchor posts to floor. Check that posts are plumb and opening is square.
2. Attach hinges (B) to door post (C) using two self drilling screws per hinge.
 - a. Note hinge placement offset detailed in Fig 1 and install tip in Fig. 2.
 - b. If necessary remove lower two 3/8" x 3" panel mounting bolts and replace with corner bolts.
 - c. Cut off and file smooth any protruding bolt threads.
 - d. Stock doors (3-1/4" sweep sp.), place bottom of hinge 7-1/4", 43-1/8", and 79" from floor.
3. Attach door panel (D) to hinges with two 3/8" x 1" bolts and nuts.
 - a. Set desired sweep space (3-1/4" for stock doors).
4. Attach pick plate (E) to door panel (D) using four self drilling screws. Note offset in Fig 1.
 - a. Pick plate should be centered over lock tongue hole. Bottom of pick plate installs 31-7/8" from bottom of stock doors.
5. Install cylinder lock (if applicable). See page 6.
6. Attach cylinder lock receiver (G) to door post (F) with two self-drilling screws.
 - a. Rolled side of receiver installs to face side of partition.
 - b. Bottom of receiver installs 41-5/8" from floor for stock doors.
 - c. If necessary remove one 3/8" x 3" panel mounting bolts from top of lower panel, and replace with corner bolt. Cut off and file smooth any protruding bolt threads.
7. Align padlock lug (H) with door padlock lug on door (D) and attach to post (F) with two self drilling screws. See page 11 for Bolt-On Angle Padlock Lugs.
8. Check operation of door, adjust as needed.

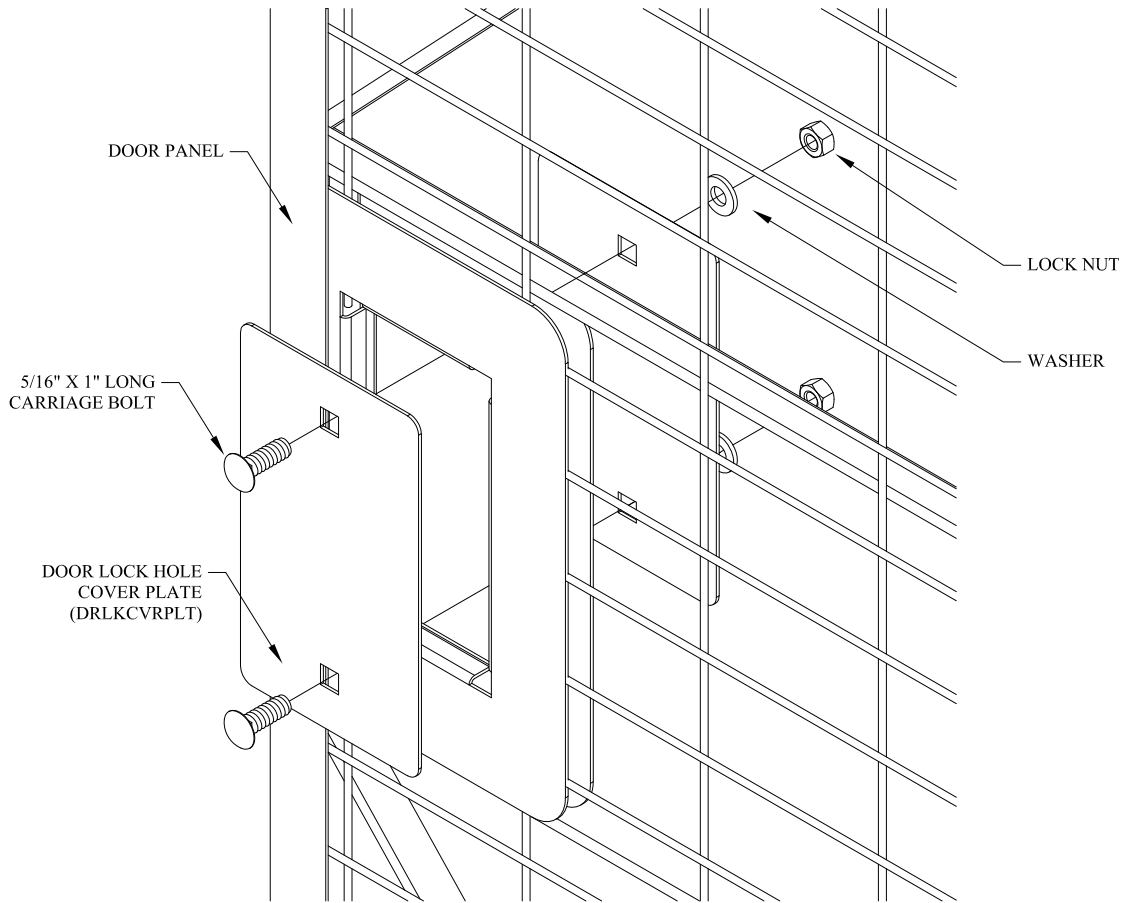

DETAIL
COVER PLATE

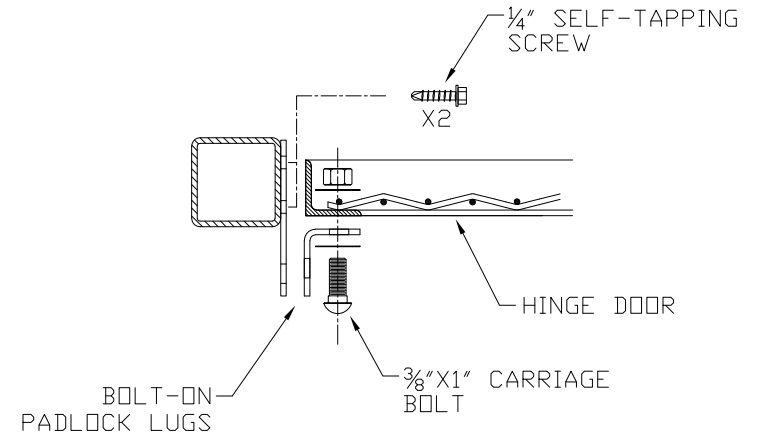

DETAIL
OPTIONAL PADLOCK LUGS

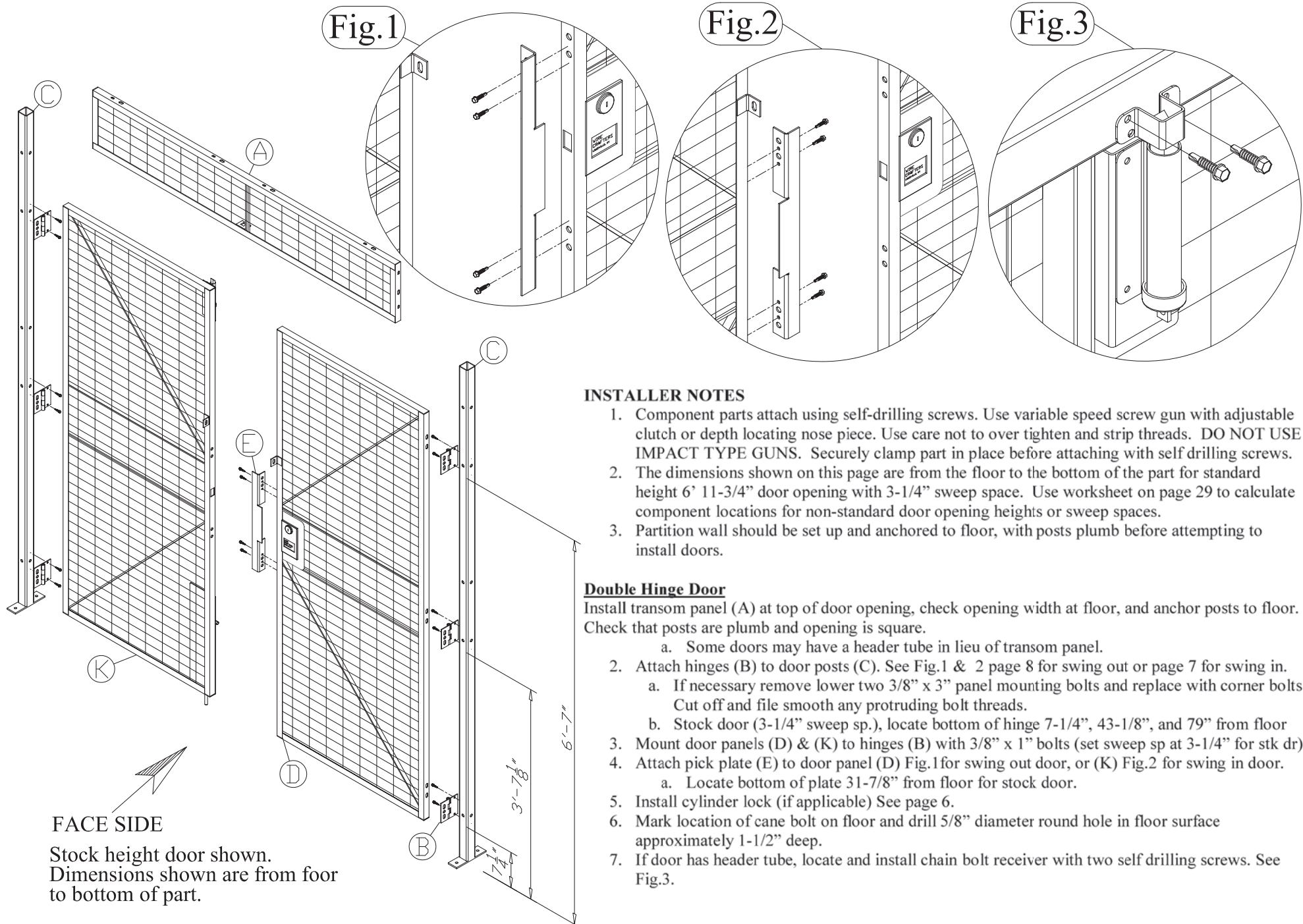

INSTALLER NOTES

1. Component parts attach using self-drilling screws. Use variable speed screw gun with adjustable clutch or depth locating nose piece. Use care not to over tighten and strip threads. **DO NOT USE IMPACT TYPE GUNS.** Securely clamp part in place before attaching with self drilling screws.
2. The dimensions shown on this page are from the floor to the bottom of the part for standard height 6' 11-3/4" door opening with 3-1/4" sweep space. Use worksheet on page 29 to calculate component locations for non-standard door opening heights or sweep spaces.
3. Partition wall should be set up and anchored to floor, with posts plumb before attempting to install doors.

Double Hinge Door

Install transom panel (A) at top of door opening, check opening width at floor, and anchor posts to floor. Check that posts are plumb and opening is square.

- a. Some doors may have a header tube in lieu of transom panel.
2. Attach hinges (B) to door posts (C). See Fig.1 & 2 page 8 for swing out or page 7 for swing in.
 - a. If necessary remove lower two 3/8" x 3" panel mounting bolts and replace with corner bolts. Cut off and file smooth any protruding bolt threads.
 - b. Stock door (3-1/4" sweep sp.), locate bottom of hinge 7-1/4", 43-1/8", and 79" from floor
 3. Mount door panels (D) & (K) to hinges (B) with 3/8" x 1" bolts (set sweep sp at 3-1/4" for stk dr).
 4. Attach pick plate (E) to door panel (D) Fig.1 for swing out door, or (K) Fig.2 for swing in door.
 - a. Locate bottom of plate 31-7/8" from floor for stock door.
 5. Install cylinder lock (if applicable) See page 6.
 6. Mark location of cane bolt on floor and drill 5/8" diameter round hole in floor surface approximately 1-1/2" deep.
 7. If door has header tube, locate and install chain bolt receiver with two self drilling screws. See Fig.3.

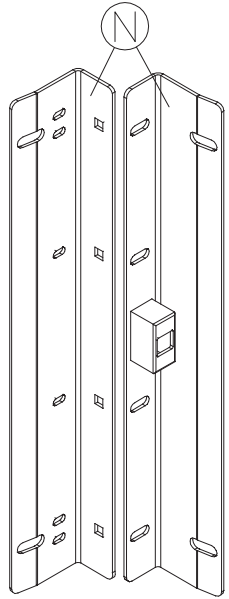

SDRECA SDRECB
Slide Door Receiver
Quantity (1)
Part# SDREC

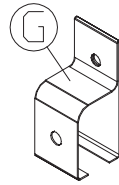

Slide Door Track Bracket
Quantity (2)
Part# SDTCBKT

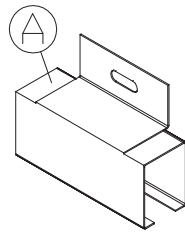

Splice Track Bracket
Quantity (1)
Part# SDTJBKT

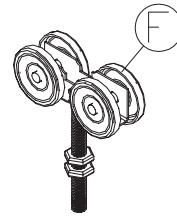

4 Wheel Trolley Truck
Quantity (2)
Part# SDTT4WH

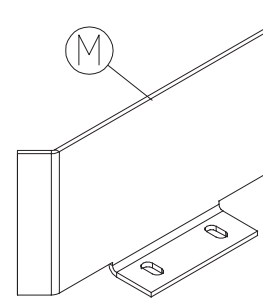

Door Guide
Quantity (1)
Part# SDDG12

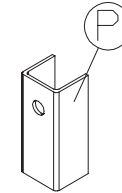

1 11/16" x 1 1/2" Channel 4" Lg.
Quantity (1)
Part# SDSDT

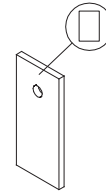

Slide Door Shim
Quantity (4)
Part# SDSCH412238

SEE SUPPLIED LOCK
MANUFACTURER INSTRUCTIONS FOR
ASSEMBLY

SDFSPK - Slide Door Fastener Pack (Contents Below)

- (35) FSHOPG- Gray Hole Plugs
- (2) COBO- 3/8" Corner Bolts
- (9) FS383- 3/8" x 3" Hex Head Cap Screw
- (2) FS381- 3/8" x 1" Hex Head Cap Screw
- (17) FS38N- 3/8" Hex Nut
- (6) FS38STA- 3/8" Wedge Anchor
- (6) FS38FW- 3/8" Flat Washer
- (1) FS38112- 3/8" x 1 1/2" Hex Head Cap Screw
- (1) FS38212- 3/8" x 2 1/2" Hex Head Cap Screw
- (1) FSTRNSPK- 1/4" x 1" Self-Drilling Screws (25) & 5/16" X 1" Carriage Bolts (4)

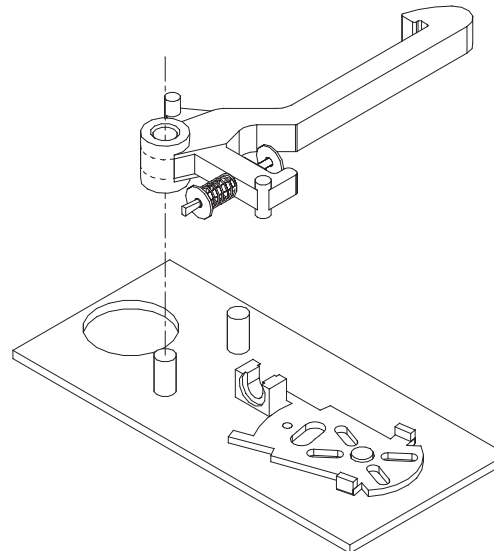

RIGHT HAND ASSEMBLY

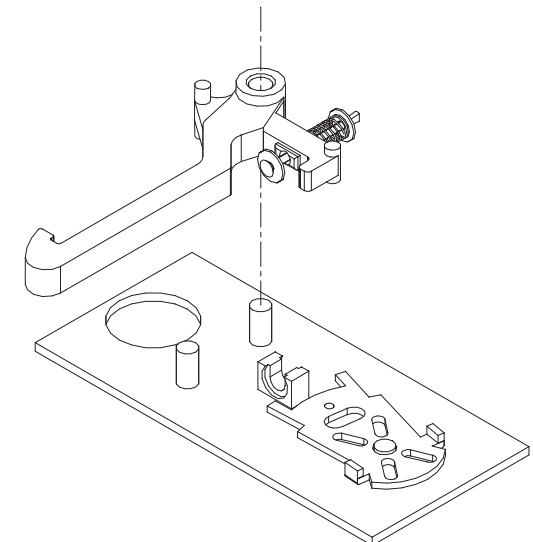

LEFT HAND ASSEMBLY

INSTALLER NOTES

1. Doors wider than 5' are made up of multiple door panels (see page 16), and use two pieces of track spliced at Splice Track Bracket (A).
2. Component parts attach using self-drilling screws. Use variable speed screw gun with adjustable clutch or depth locating nose piece. Use care not to over tighten and strip threads. **DO NOT USE IMPACT TYPE GUNS.** Securely clamp part in place before attaching with self drilling screws.
3. Partition wall should be set up and anchored to floor. It is **CRITICAL** that posts are plumb and in line. Door opening should be square.

Outside Slide Door

1. Check that door posts are anchored and plumb.
2. Using a 3/8" x 3" bolt, install Splice Track Bracket (A) on face side of door post (B) opposite door receiver post (C). Note: if enclosure has ceiling use a 3/8" x 1" bolt to attach bracket see Fig.1.
3. Place two 4 wheel trolley trucks (F) into track (D). Using one 3/8" x 1" bolt, attach track bracket (G-1) to track.
 - a. Check that trucks roll freely in track.
4. Slide open end of track (D) into Splice Track Bracket (A). Using one 3/8" x 3" bolt, attach track bracket (G-1) to receiver post (C) see Fig 2.
5. Invert Track Bracket (G-2) and attach to far end of Track (D) using one 3/8" x 1" bolt. If end of track aligns with post, do not invert track bracket.
 - a. For doors wider than 5'
 - i. Attach inverted bracket to far end of second track section.
 - ii. Slide open end of second track section (D) into open end of Splice Track Bracket (A).
6. Using one 3/8" x 1-1/2" bolt and two slide door shims (O), attach the inverted track bracket on the far end of Track (D) to the wire mesh panel.
 - a. Per Fig. 3 place one flat slide door shim between the Track Bracket (G-2) and the mesh, and the other Slide Door Shim on the inside of the mesh and fasten in place with one 3/8" x 1-1/2" bolt and hex nut. **TRACK MUST BE LEVEL.**
 - b. Should Track Bracket (G-2) align with post, attach upright track bracket to post with 3/8" bolt.
7. For doors wider than 5' or taller than 8', assemble door panels to form door assembly. See Slide Door Panel Assembly page 16.
8. Hang door (I) on Trolley Trucks.
 - a. Two 9/16" round holes on top of door assembly match trolley bolts.
 - b. Trolley bolts should have one nut above and below door frame; upper "jam" nut should be backed off until door operation is finalized.
9. Lag door guide (M) to floor with two floor anchors see Fig 4.
10. Raise door to desired sweep space using lower trolley nut.
 - a. Stock doors without lower angle cover bar have 3-1/4" sweep space.
 - b. Stock doors with lower angle cover bar have 1-3/4" sweep space.
 - c. Door must be level for proper operation.
11. Door should slide freely, if not check that trolley trucks are properly aligned in track.
12. If applicable, install cylinder lock in door, see page 11.
13. Install Lock Receiver (N). See Fig 5. and slide door receiver instructions on page 17.
14. Fine tune door by tightening/loosening trolley truck nuts.
 - a. When door operates smoothly and locks consistently, tighten top jam nut.
 - b. Be sure not to cock trolleys sideways when tightening jam nut. It may be necessary to hold bolt with pliers while tightening jam nut.

NOTE: 10' High Doors, See Page 23

PARTIAL MESH SHOWN FOR CLARITY

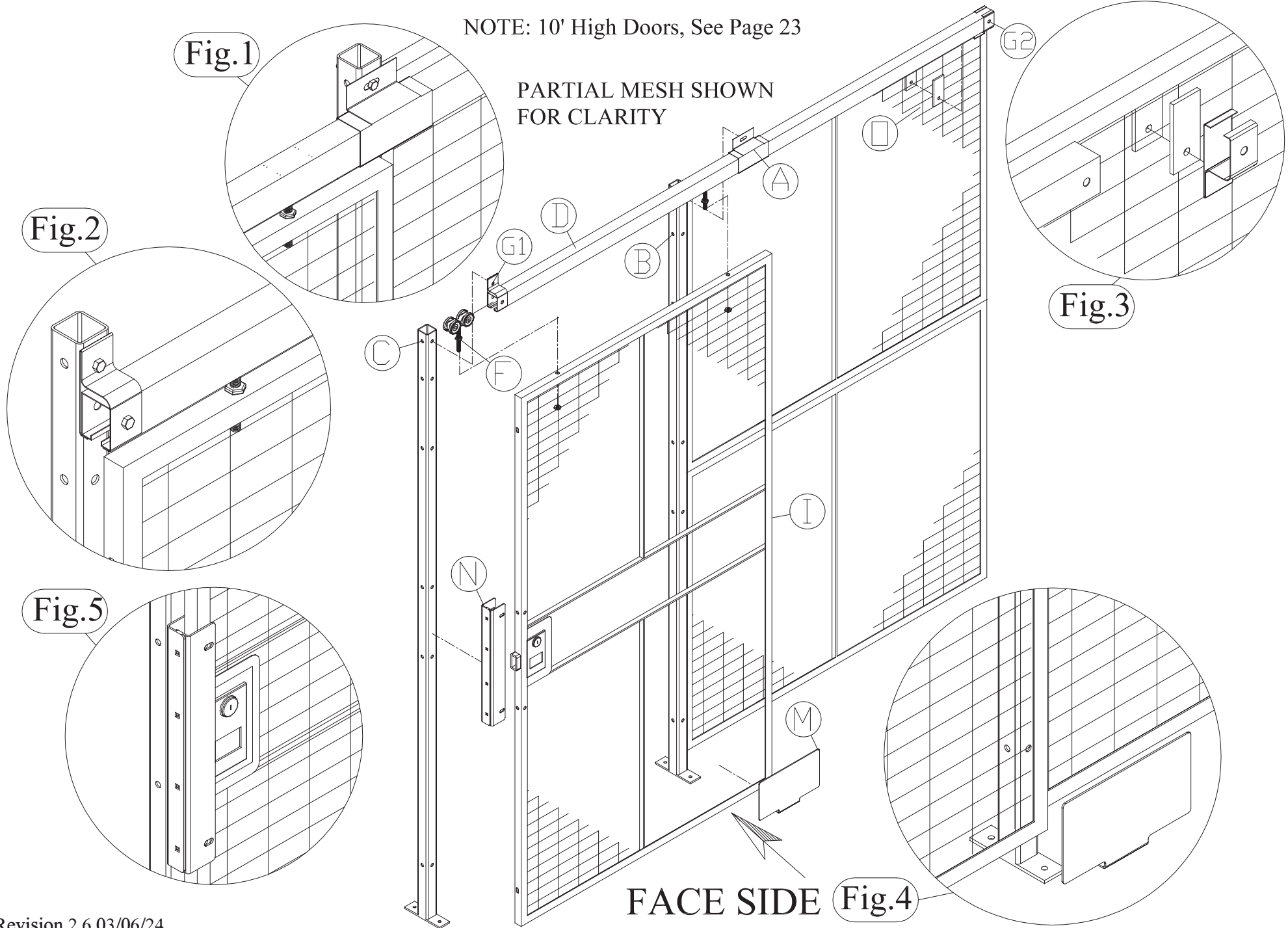

INSTALLER NOTES

1. Doors wider than 5' are made up of multiple door panels (see page 16), and use two pieces of track spliced at Track Bracket (A).
2. Component parts attach using self-drilling screws. Use variable speed screw gun with adjustable clutch or depth locating nose piece. Use care not to over tighten and strip threads. **DO NOT USE IMPACT TYPE GUNS.** Securely clamp part in place before attaching with self drilling screws.
3. Partition wall should be set up and anchored to floor. It is **CRITICAL** that posts are plumb and in line. Door opening should be square.

Inside Slide Door

1. Check that door posts are anchored and plumb.
2. Using a 3/8" x 3" bolt and one Slide Door Shim(O), install Splice Track Bracket (A) on inside of door post (B) opposite door receiver post (C). Place the shim between the bracket and the post. Note: If enclosure has ceiling, use a 3/8" x 1" bolt to attach bracket see Fig.1.
3. Place two 4 wheel trolley trucks (F) into track (D). Using one 3/8" x 1" bolt attach track bracket (G1) to track.
 - a. Check that trucks roll freely in track.
4. Slide open end of track (D) into Splice Track Bracket (A). Using one 3/8" x 3" bolt and one Slide Door Shim (O), attach track bracket (G1) to inside of receiver post (C) see Fig 2.
5. Invert Track Bracket (G2) and attach to far end of Track (D) using one 3/8" x 1" bolt. If end of track aligns with post, do not invert track bracket.
 - a. For doors wider than 5'
 - i. Attach inverted bracket to far end of second track section.
 - ii. Slide open end of second track section (D) into open end of Splice Track Bracket (A).
6. Using one 3/8" x 2-1/2" bolt, one slide door shim (O) and one 2" Slide Door Spacer (P), attach the inverted track bracket on the far end of Track (D) to the wire mesh panel. **TRACK MUST BE LEVEL.**
 - a. Per Fig. 3 place one 2" Slide Door Spacer between the Track Bracket and the mesh, and the Slide Door Shim on the outside of the mesh and fasten in place with one 3/8" x 2-1/2" bolt and hex nut.
 - b. Should Track Bracket (G-2) align with post, attach upright track bracket to post with 3/8" bolt.
7. For doors wider than 5' or taller than 8', assemble door panels to form door assembly. See Slide Door Panel Assembly page 16.
8. Hang door (I) on Trolley Trucks.
 - a. Two 9/16" round holes on top of door assembly match trolley bolts.
 - b. Trolley bolts should have one nut above and below door frame; upper "jam" nut should be backed off until door operation is finalized.
9. Lag door guide (M) to floor with two floor anchors see Fig 4.
10. Raise door to desired sweep space using lower trolley nut.
 - a. Stock doors without lower angle cover bar have 3-1/4" sweep space.
 - b. Stock doors with lower angle cover bar have 1-3/4" sweep space.
 - c. Door must be level for proper operation.
11. Door should slide freely. If not check that trolley trucks are properly aligned in track.
12. If applicable, install cylinder lock in door, see page 11.
13. Install Lock Receiver (N). See Fig.5 and Slide Door Receiver instruction on page 17.
14. Fine tune door by tightening/loosening trolley truck nuts.
 - a. When door operates smoothly and locks consistently, tighten top jam nut.
 - b. Be sure not to cock trolleys sideways when tightening jam nut. It may be necessary to hold bolt with pliers while tightening jam nut.

NOTE: 10' High Doors, See Page 23

PARTIAL MESH SHOWN FOR CLARITY

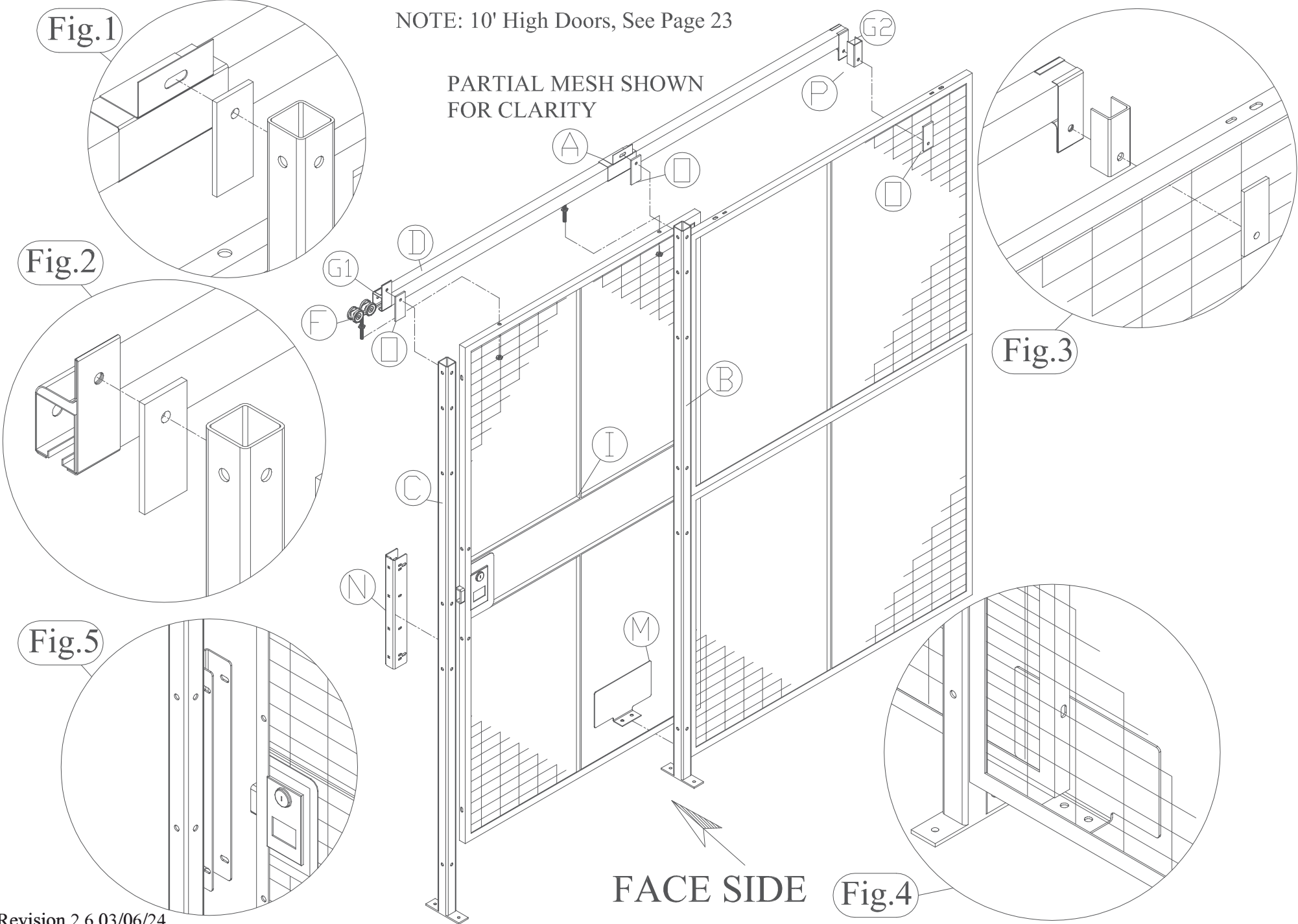

WireCrafters

6' or Wider Slide Door Panel Assembly

NOTE: Part (C) DEP for 10'
High Doors Only

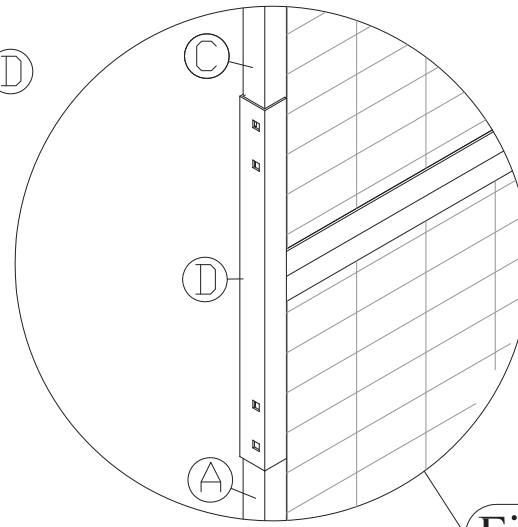
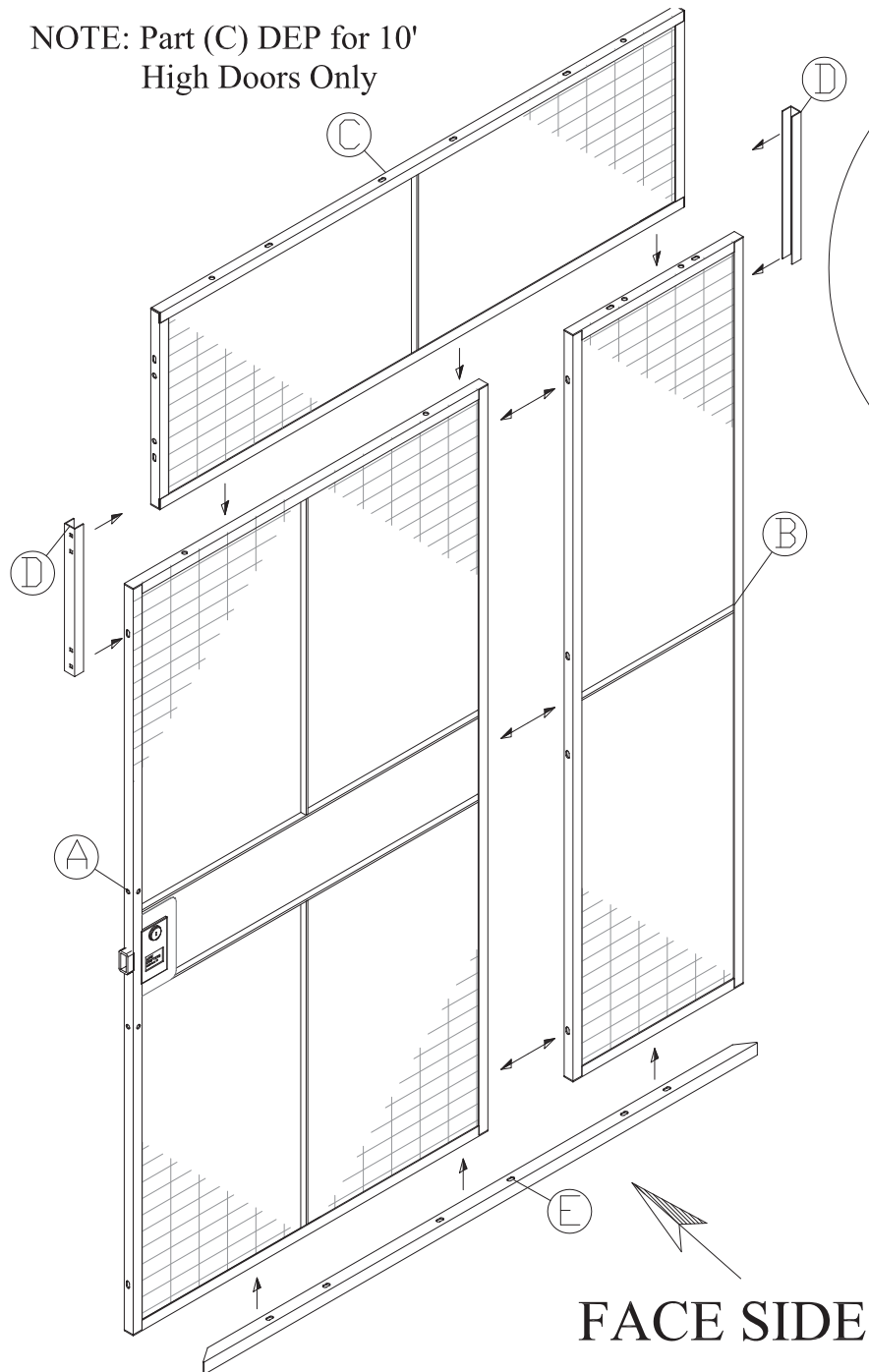

10' High Doors or Taller

Fig. 1

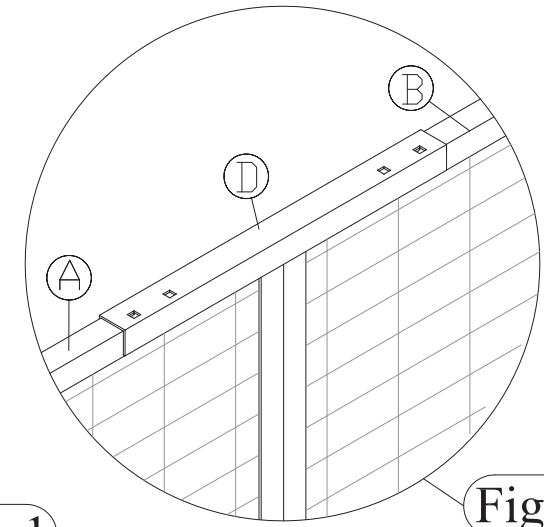

8' High Doors or Shorter

Fig. 2

SLIDE DOOR PANEL ASSEMBLY

1. Attach door panel (A) to leaf panel(s) (B) with 3/8" x 1" bolts.
 - a. 10' wide doors have 4' 2" wide door panel, 4' wide leaf panel, and 2' wide leaf panel.
2. For 10' high doors, attach 2' high DEP panel (C)
 - a. Attach two 18" DEP Channels (D) with 3/8" x 1" carriage bolts to splice connection between door and DEP see Fig.1.
3. For 8' high doors, attach one 18" DEP Channel (D) per joint, to top frame with 3/8" x 1" carriage bolts, see Fig.2.
4. Attach lower angle cover bar (E) to bottom of door with 3/8" bolts and nuts.

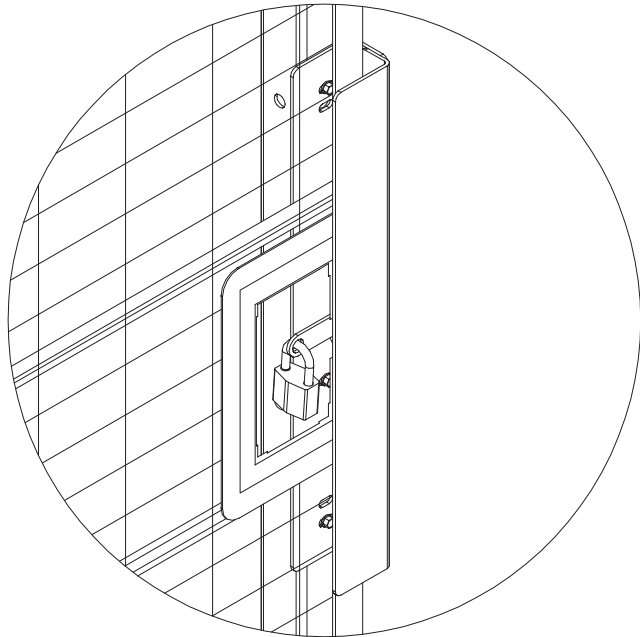

SEE NEXT PAGE FOR
PADLOCK LUG

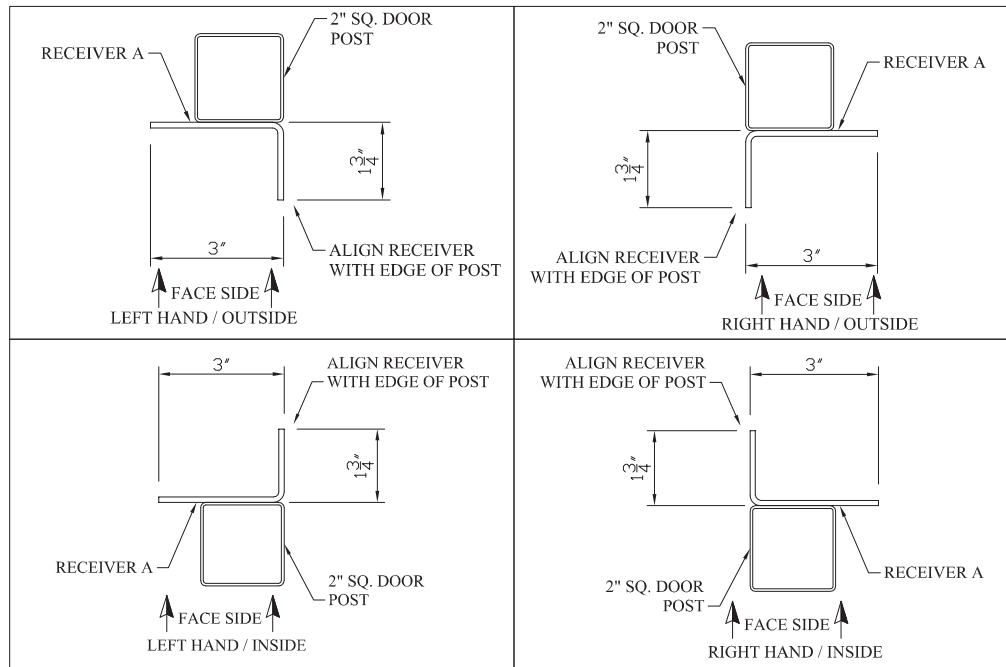
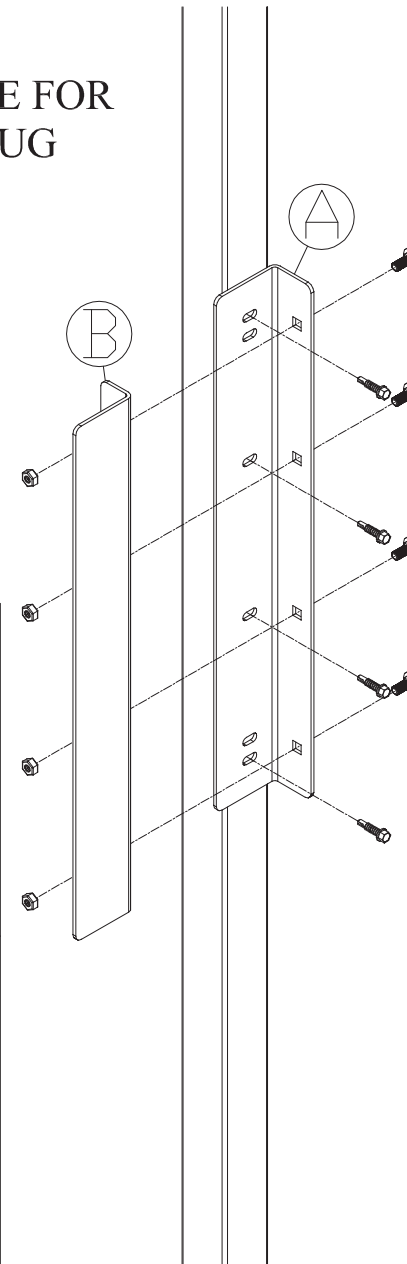

Fig.1



Note:

Component parts attach using self-drilling screws. Use variable speed screw gun with adjustable clutch or depth locating nose piece when installing self-drilling screws. **DO NOT USE IMPACT TYPE GUNS.**

RECEIVER LOCATION :

1. Measure from floor to center of the installed slide door's lock opening—normally 49" for stock doors.
 - a. Be sure proper sweep space has been set before measuring.
2. Subtract 10" from the above measurement to get the dimension from the floor to the bottom of Lock Receiver (A)—normally 39" for stock doors.
 - a. Mark post.
3. Place leg of Lock Receiver (A) with eight slotted holes against receiver post.
 - a. See Fig.1 for receiver (A) orientation.
 - b. Align bottom of receiver with spot marked in Step 2 above.
4. Align opposing leg of Lock Receiver (A) with square holes with edge of post.
5. Attach Lock Receiver (A) to door post with four self-drilling screws.
6. Using four 5/16" x 1" carriage bolts, securely attach Lock Receiver (B) to (A).
7. Fine tune door up or down so that the door's tubular lock tongue guard overlaps lock receiver tube. **DOOR MUST BE LEVEL.**

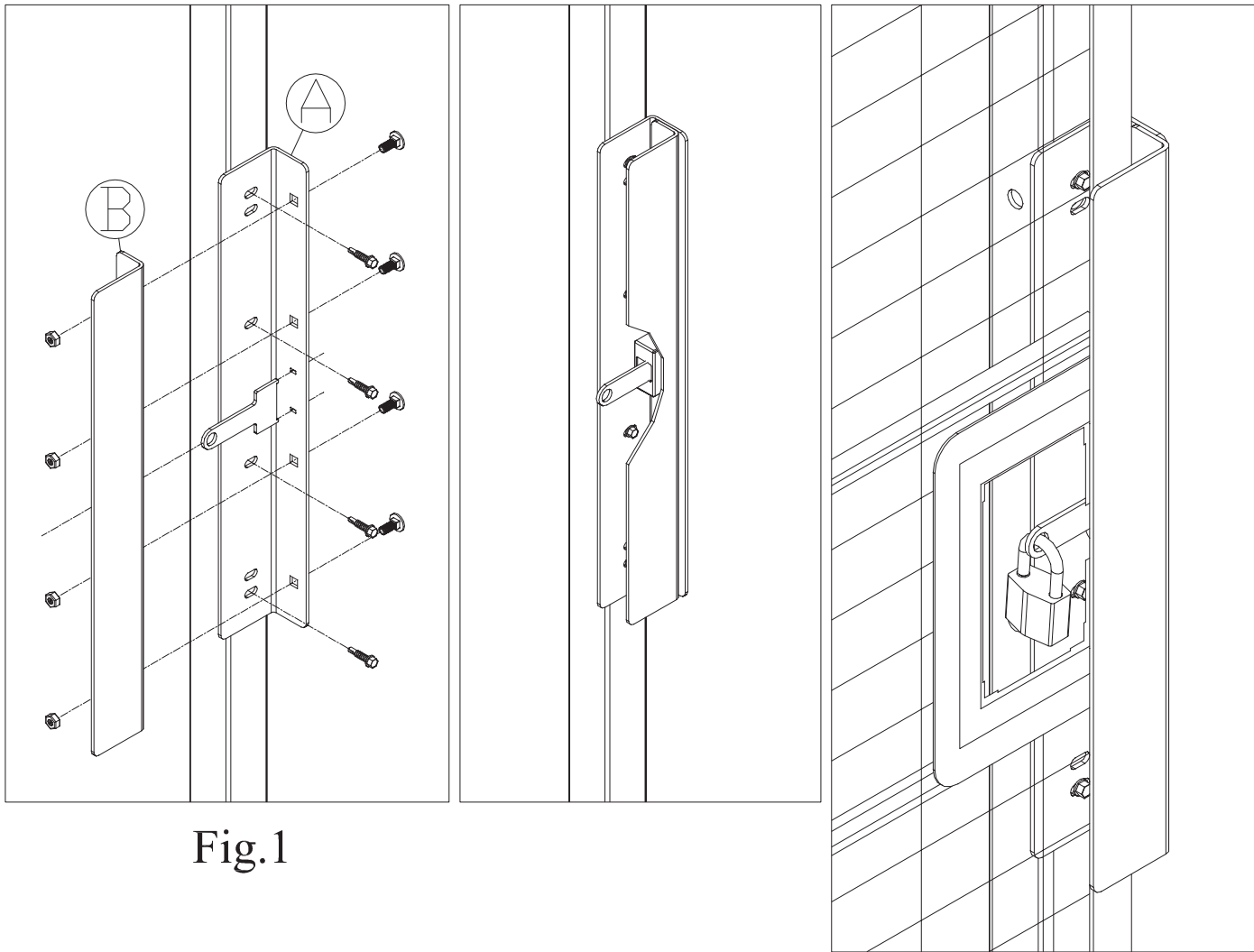

Fig.1

TYPICAL SLIDE DOOR
PADLOCK LUG CONNECTION

Note:

Component parts attach using self-drilling screws. Use variable speed screw gun with adjustable clutch or depth locating nose piece when installing self-drilling screws. **DO NOT USE IMPACT TYPE GUNS.**

RECEIVER LOCATION:

1. Measure from floor to center of the installed slide door's lock opening—normally 49" for stock doors.
 - a. Be sure proper sweep space has been set before measuring.
2. Subtract 10" from the above measurement to get the dimension from the floor to the bottom of Lock Receiver (A)—normally 39" for stock doors.
 - a. Mark post.
3. Place leg of Lock Receiver (A) with eight slotted holes against receiver post.
 - a. See Fig.1 for receiver (A) orientation.
 - b. Align bottom of receiver with spot marked in Step 2 above.
4. Align opposing leg of Lock Receiver (A) with square holes with edge of post.
5. Attach Lock Receiver (A) to door post with four self-drilling screws.
6. Slide SDPLL through slotted hole in Receiver (B)
7. Using four 5/16" x 1" carriage bolts, securely attach Lock Receiver (B) to (A).
8. See "Hinge Door Lock Cover Plate" to cover opening if desire.

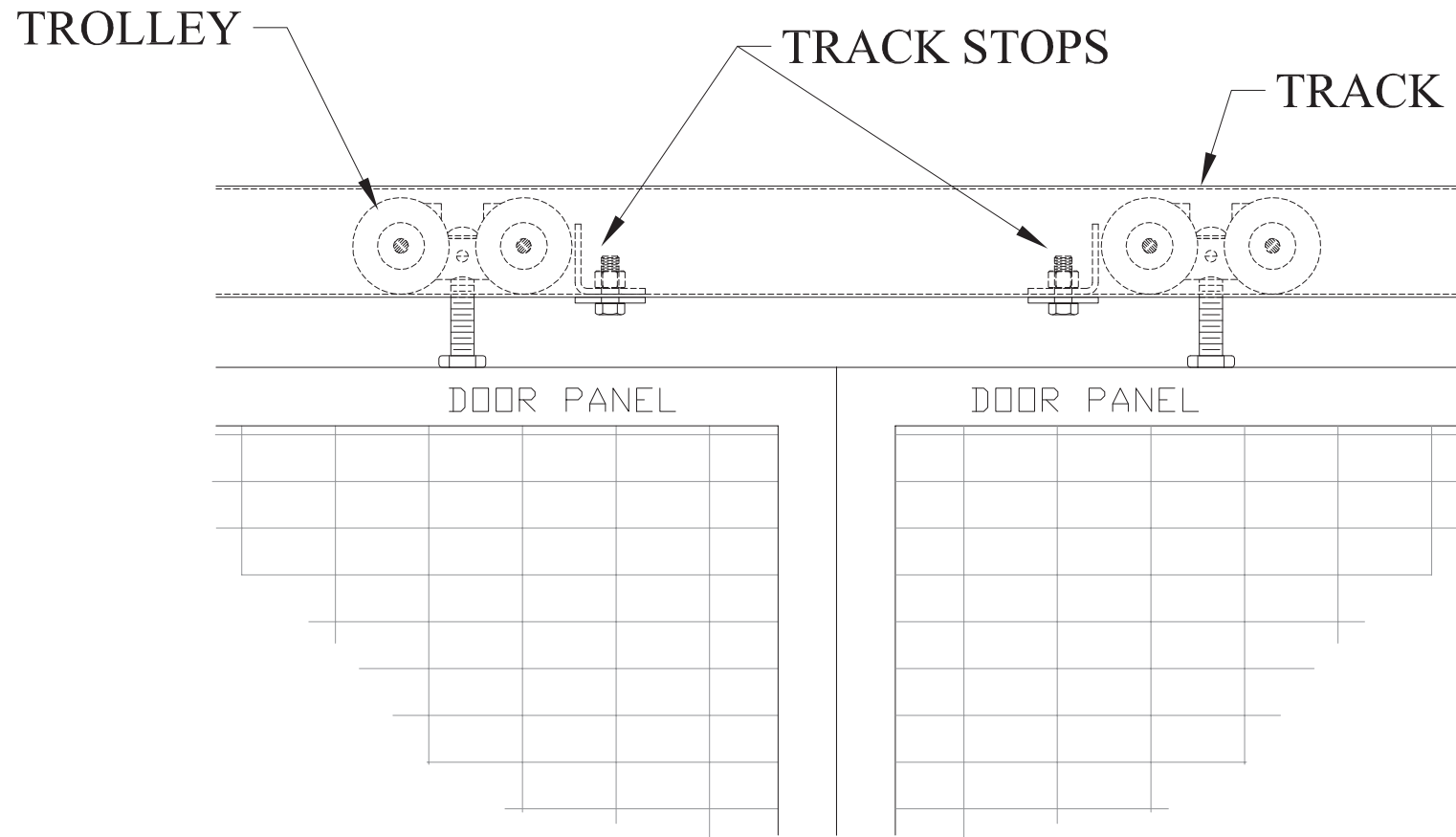

TRACK STOP PARTS

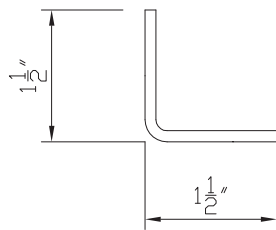

ANGLE CLIP

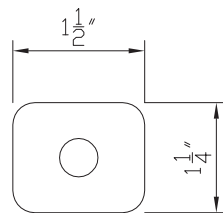

FLAT



$\frac{3}{8}'' \times 1''$ BOLT & NUT

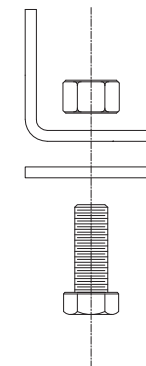

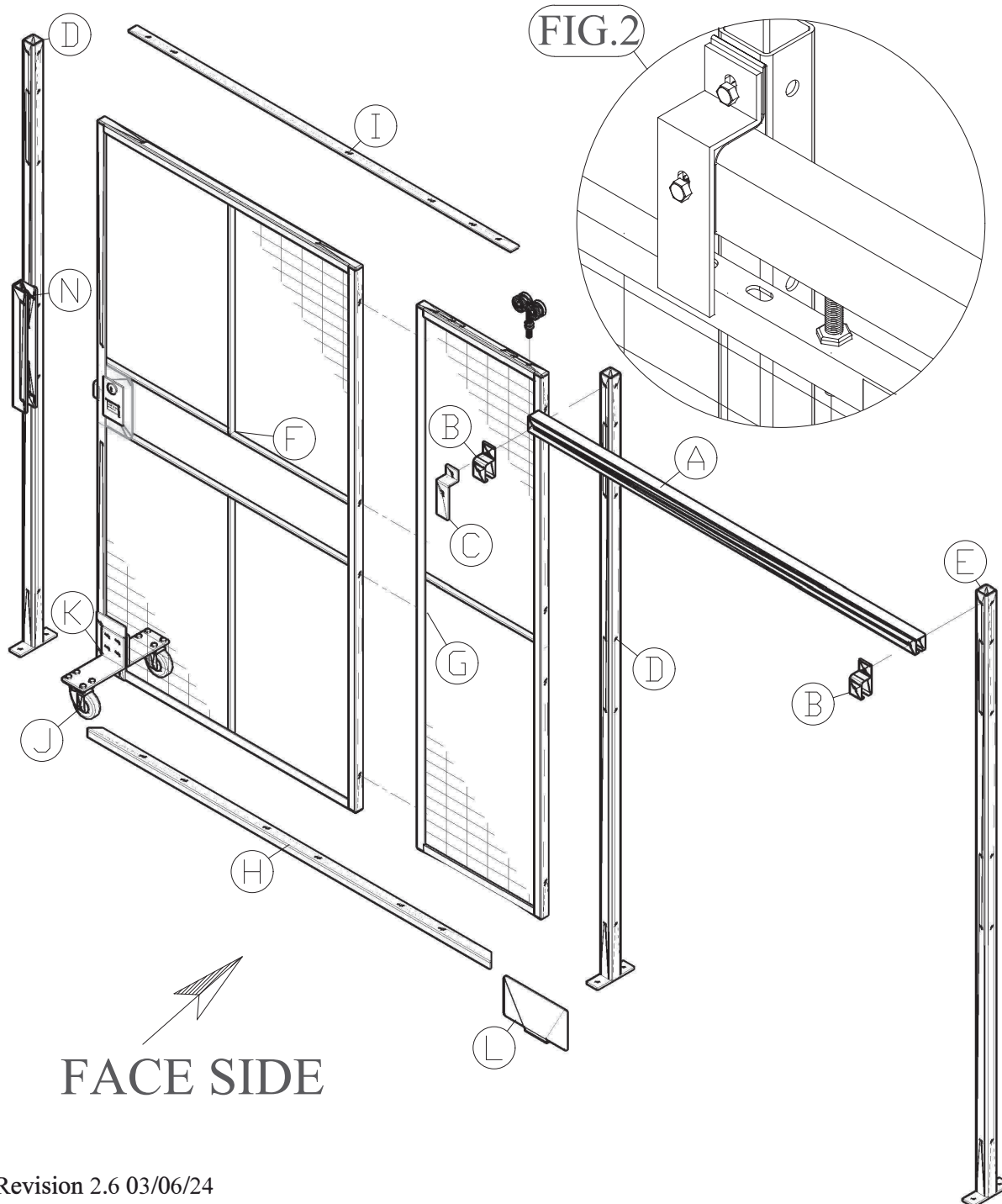

INSTALLER NOTES

1. Component parts attach using self-drilling screws. Use variable speed screw gun with adjustable clutch or depth locating nose piece. Use care not to over tighten and strip threads. **DO NOT USE IMPACT TYPE GUNS.** Securely clamp part in place before attaching with self drilling screws.
2. Partition wall should be set up and anchored to floor. It is **CRITICAL** that posts are plumb and in line. Door opening should be square.

Tunnel Door

1. Check that all posts are anchored and plumb.
2. Place one four wheeled trolley truck in track (A).
3. Using 3/8" x 1" bolt, attach Track Bracket (B) and Z-Bracket (C) to leading end of track (A) see Fig.2.
4. Attach second Track Bracket (B) to far end of track (A) using 3/8" x 1" bolt.
5. Mount track assembly to Posts (D) and (E) with 3/8" x 3" bolts and nuts.
 - a. If enclosure has ceiling use 3/8" x 1" bolts to attach track brackets.
6. Assemble door panels if applicable.
 - a. Bolt door panel (F) to door leaf (G). (Some doors have multiple panels.)
 - b. Bolt Angle Cover Bar (H) to bottom of door panels (F) & (G).
 - c. Bolt Flat Cover Bar (I) to top of door panels (F) and (G).
7. Install cylinder lock (if applicable). See page 11 for instructions.
8. Mount caster plate (P) to door panel (F) with four 1/4" self-drilling screws. See Fig.1 for location. Alternately, drill four 7/16" diameter holes and attach using 3/8" carriage bolts.
9. Mount casters (J) to caster plates (K), (two per door) with 5/16" x 1" bolts.
10. Mount caster plate assemblies to door panel (P) using 3/8" x 1 1/2" bolts (use 2 washers for each bolt) see Fig. 1.
11. Bolt trailing end of door to trolley inside of track (A) so that door is level.
12. Lag Door Guide (L) to floor using two 3/8" anchors.
13. Mount receiver (N). Refer to section labeled as "Slide Door Receiver" of this manual.
14. Check door operation so that it rolls smoothly, and latch engages and locks
 - a. Adjust caster plates and trolley bolt if necessary.
15. Tighten upper jam nut on trolley truck
 - a. Do not cock trolley in track when tightening jam nut. It may be necessary to hold bolt while tightening.

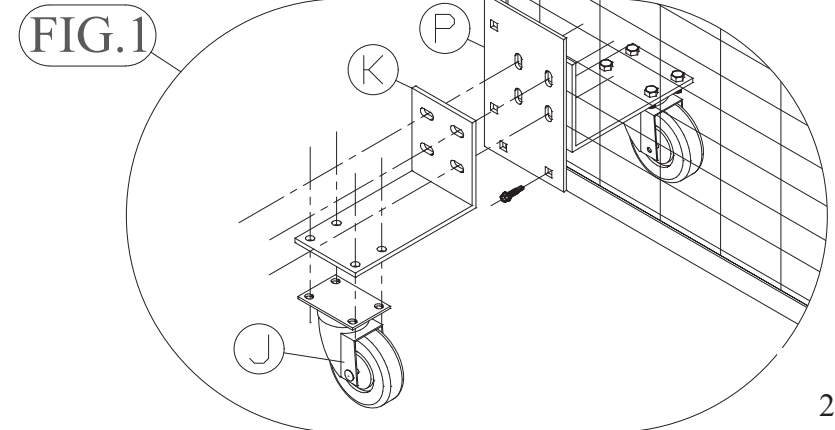

FACE SIDE

INSTALL SLOTTED ANGLE

1. Cut slotted angle 1/2" shorter than panel width.
2. Install slotted angle on the top panel with one leg up to the inside of the enclosure or wall using 3/8" x 1" bolts.
3. Lift panels into place, face side up, and bolt to slotted angle with 3/8" x 1" bolts.

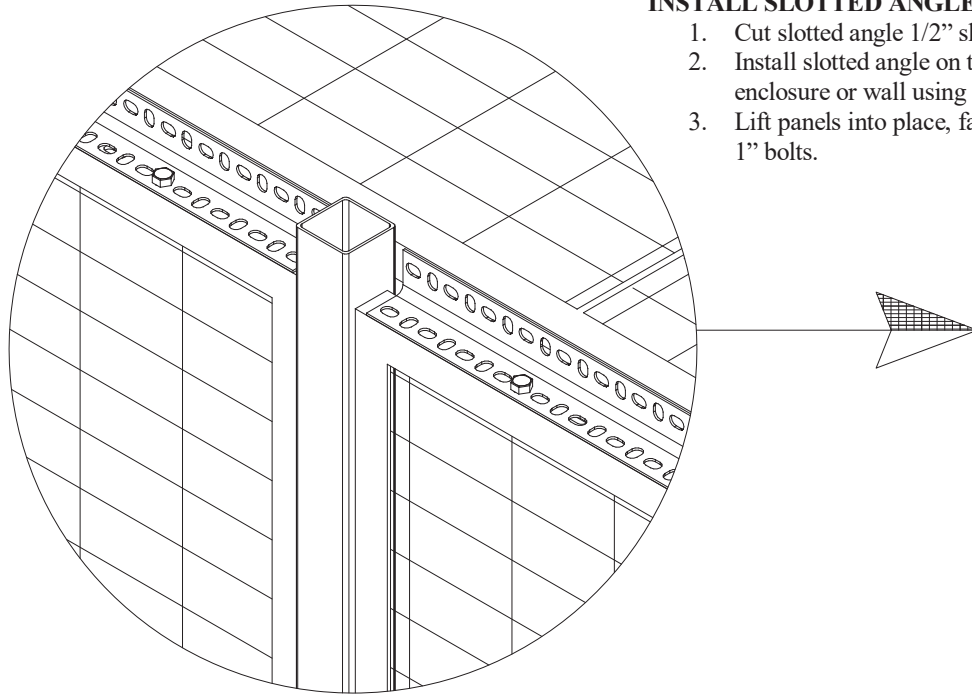

SLOTTED ANGLE

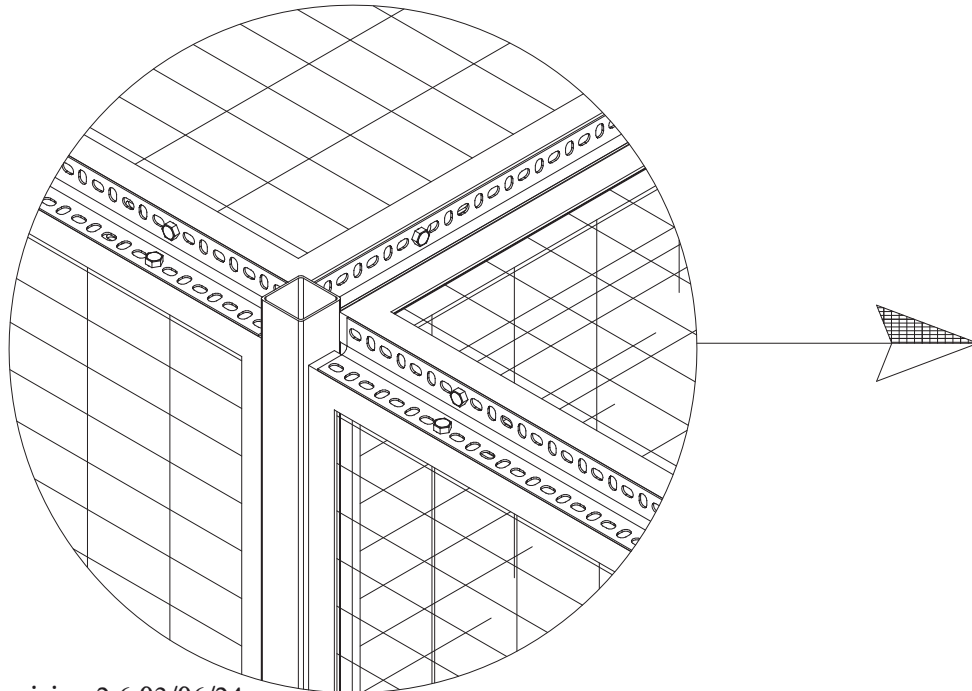
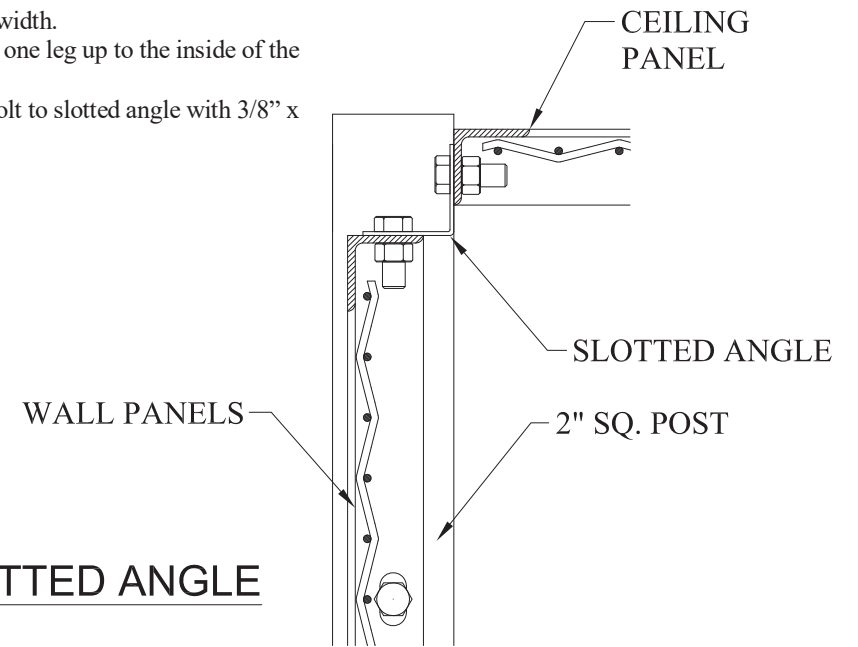

DOUBLE-SLOTTED ANGLE

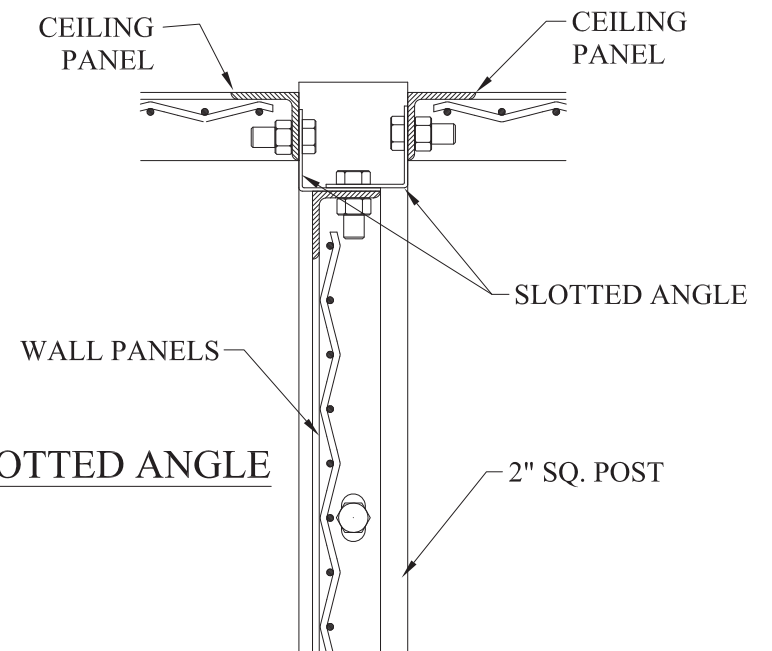

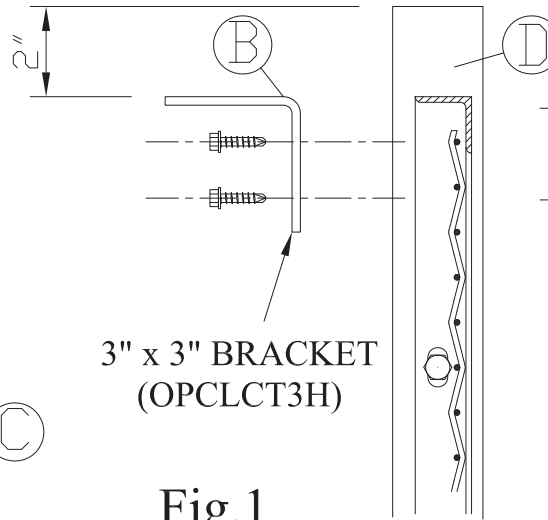
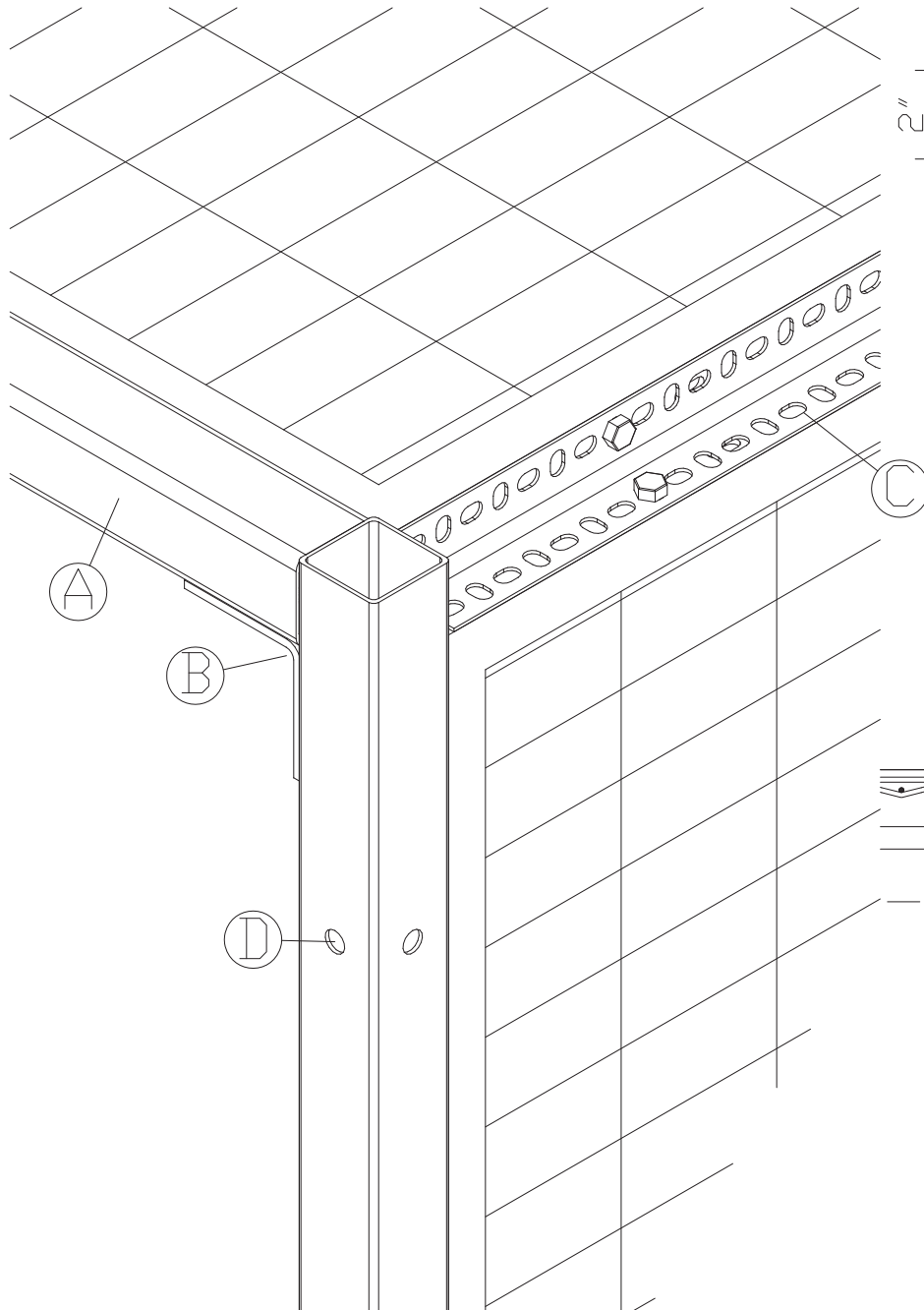

Fig.1

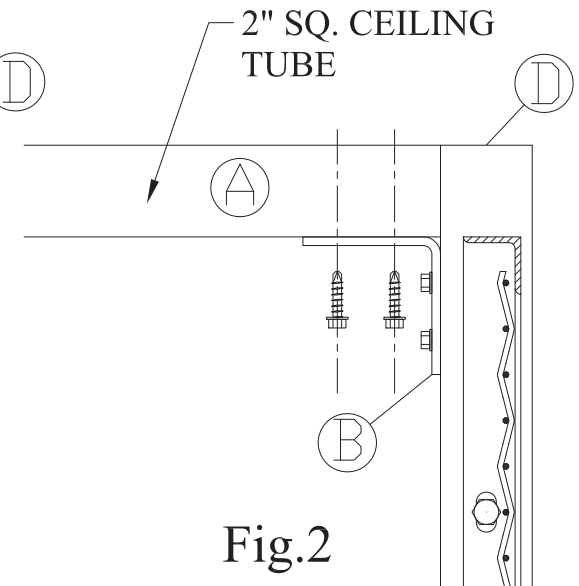

Fig.2

2" x 2" CEILING TUBE

1. Note overall layout of ceiling.
2. Identify location(s) of 2" x 2" horizontal ceiling tube(s) (A).
3. Using two self drilling screws, center and attach one 3/16" x 1-3/4" x 3" ceiling bracket (B) on posts (D) where horizontal ceiling tubes are to be installed.
 - a. Place so that leg of ceiling bracket is flush with top leg of wall panel per Fig.1.
 - b. Clamp part in place before using self drilling screws.
4. Align horizontal ceiling tube (A) with posts (D), attach to bracket (B) with self-drilling screws per Fig.2.
 - a. See detail page 23 if one end of ceiling tube mounts directly to building wall.
5. Install slotted angle (C) on top of wall panels per instruction page 19.
6. Lift panels into place, face side up, and attach to slotted angle with 3/8" x 1" bolts.
7. Use self drilling screws to attach panels to horizontal ceiling tubes Fig.3.
 - a. Position panels to eliminate any sag in ceiling before fastening in place.

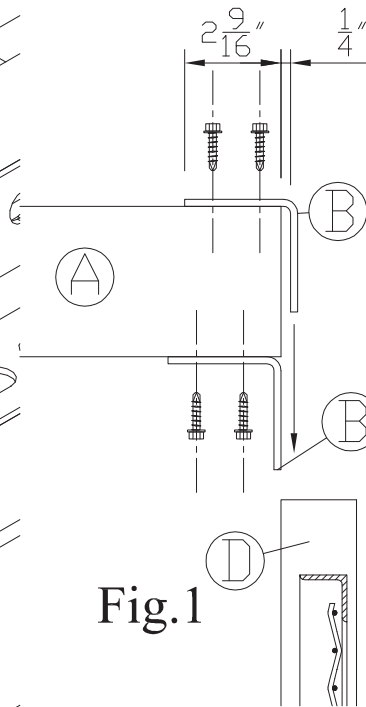
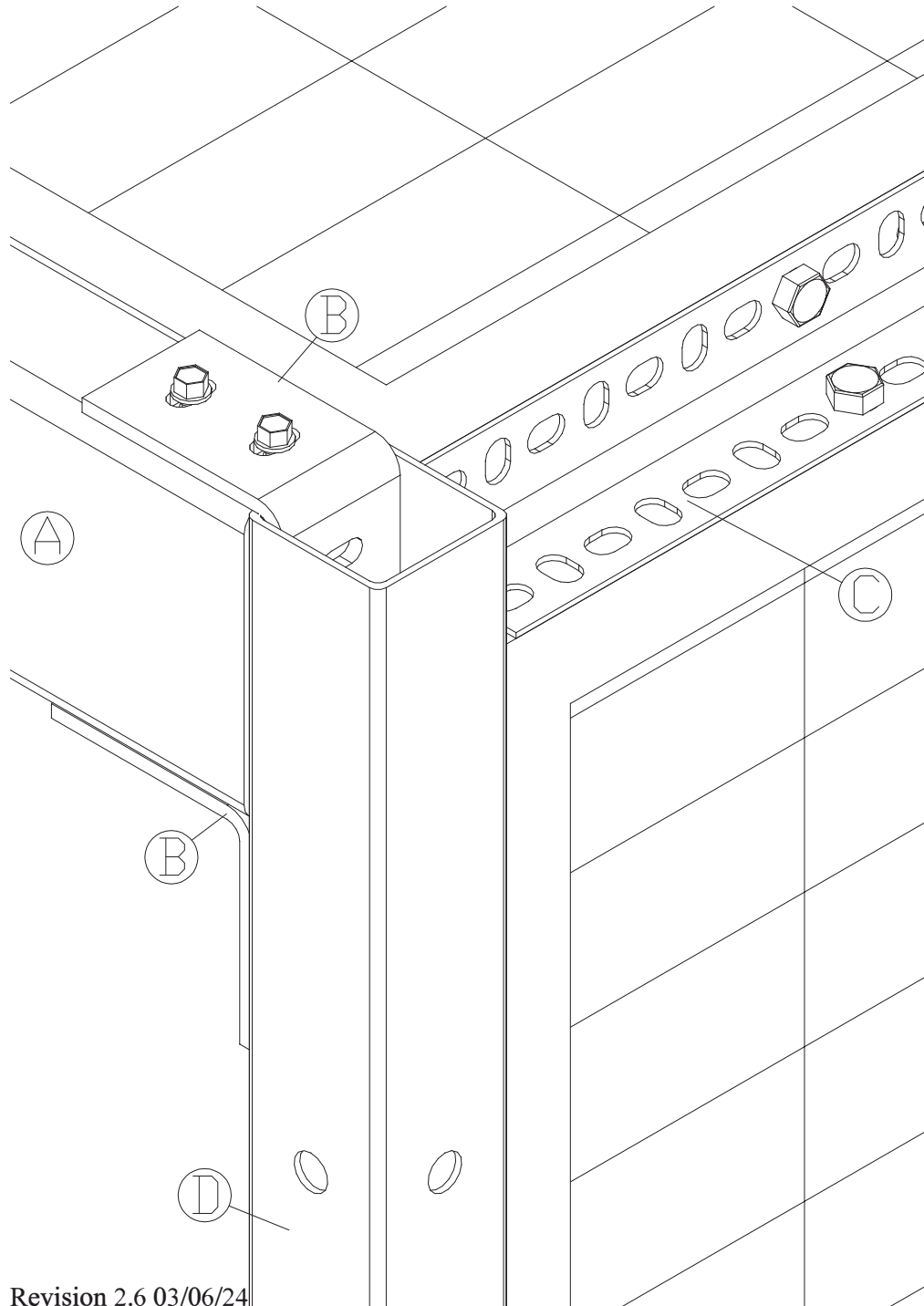

Fig.1

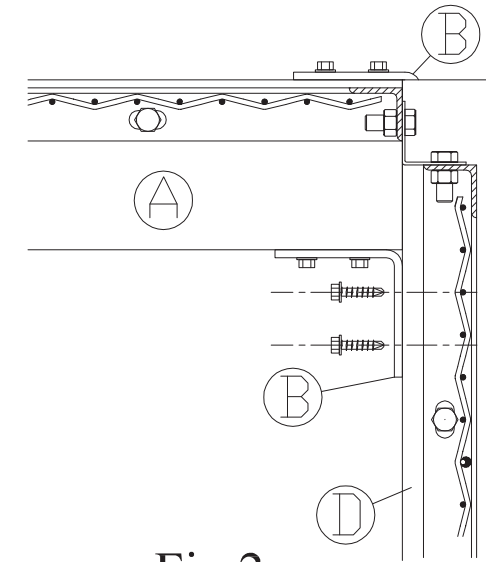

Fig.2

2" X 4" CEILING TUBE

1. Note location(s) of 2" x 4" horizontal ceiling tube(s) (A).
2. Center and attach one 3/16" x 1-3/4" x 3" Angle Bracket (B) to the top 2" side of 2" x 4" Ceiling Tube with two self-drill screws so that bracket leg hangs over the tube's open end.
 - a. Leave 1/4" gap between tube end and bracket leg per Fig.1.
3. Center and attach a second 3/16" x 1-3/4" x 3" Angle Bracket (B) to the bottom side of the 2" x 4" ceiling tube so that the bracket leg is flush with the end of the tube.
 - a. Both bracket legs should be pointing in the same direction. See Fig.1.
4. If opposite end of tube attaches to a post, repeat steps 2 & 3 for the opposite end of tube.
 - a. See detail page 23 if one end of ceiling tube mounts directly to building wall.
5. Lift ceiling tube (A) above the partition wall post (D) and lower into place so that the top bracket fits inside of wall post (D) Per Fig.2.
6. Align ceiling tube (A) with wall post (D) and secure lower bracket to post using self drilling screws see Fig.2
7. Install slotted angle on top of wall panels per instruction page 19.
8. Lift panels into place, face side up, and attach to slotted angle (C) with 3/8" x 1" bolts (see Fig.3 page 20).
9. Attach panels to ceiling Tube using 3/8" x 3" bolts.
 - a. Position panels to eliminate any sag in ceiling before fastening in place.

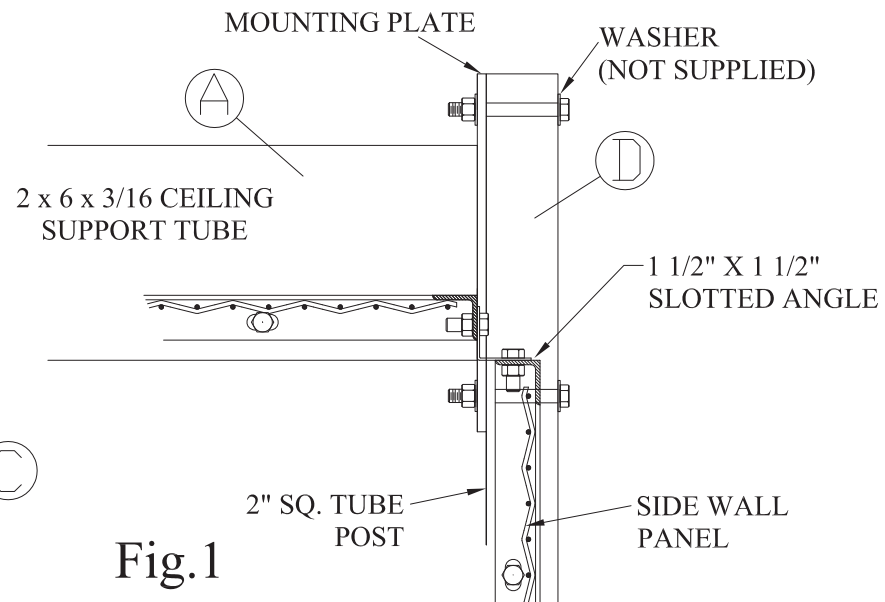
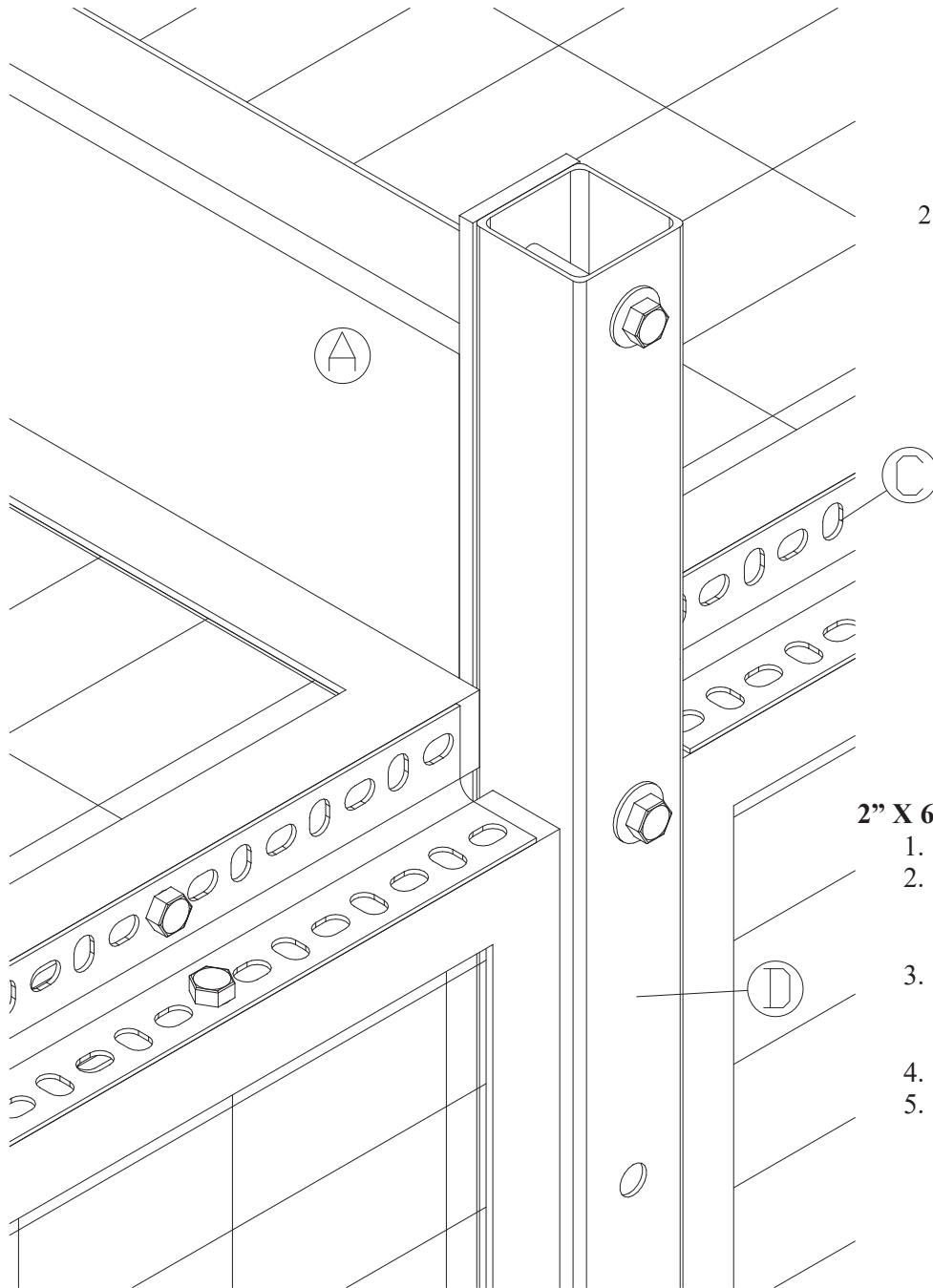
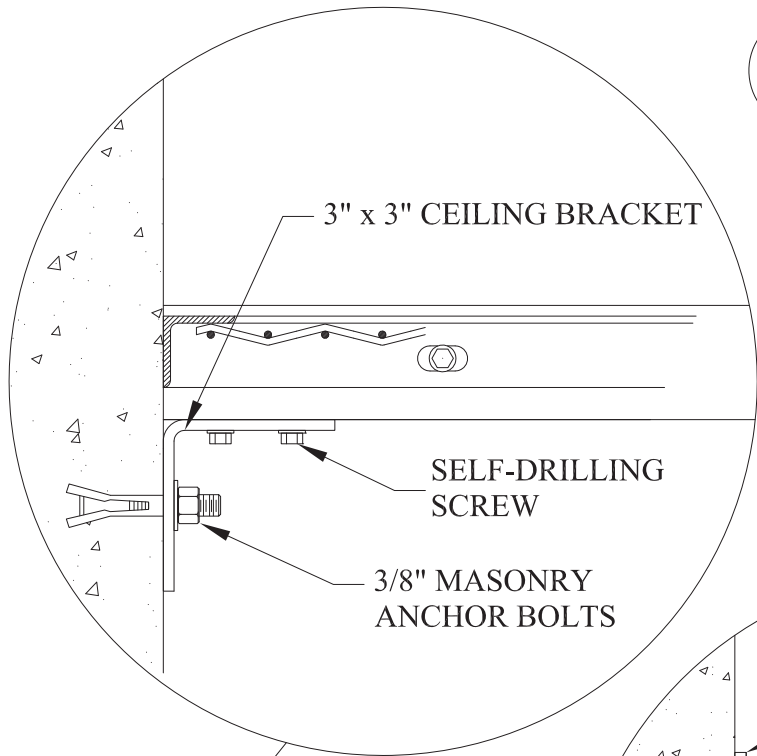

Fig. 1

2" X 6" CEILING TUBE

1. Note location(s) of 2" x 6" horizontal ceiling tube(s) (A).
2. Lift ceiling tube (A) so that holes in mounting plates match holes at top of partition wall post (D).
 - a. See detail page 23 if one end of ceiling tube mounts directly to building wall.
3. Connect ceiling tube to wall post with two 3/8" x 3" bolts and nuts, and tighten securely.
 - a. Installer: use 3/8" flat washer (not provided) on nut and bolt side see Fig.1
4. Install slotted angle (C) on top of wall panels per instruction page 19.
5. Use 3/8" x 3" bolts to attach ceiling panels to 2" x 6" ceiling tube.



2" X 2" TUBE CONNECTION TO MASONRY WALL

2" X 4" TUBE CONNECTION TO MASONRY WALL

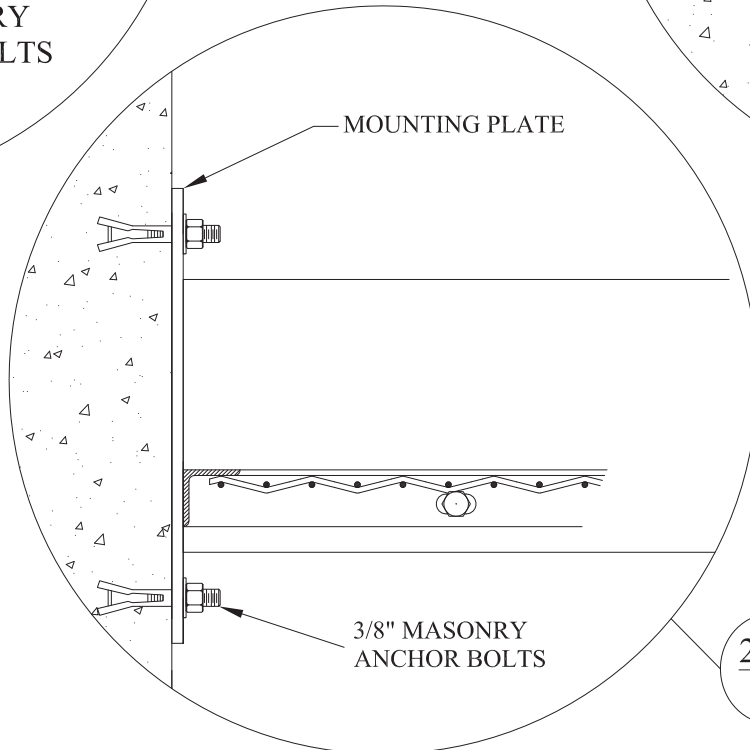
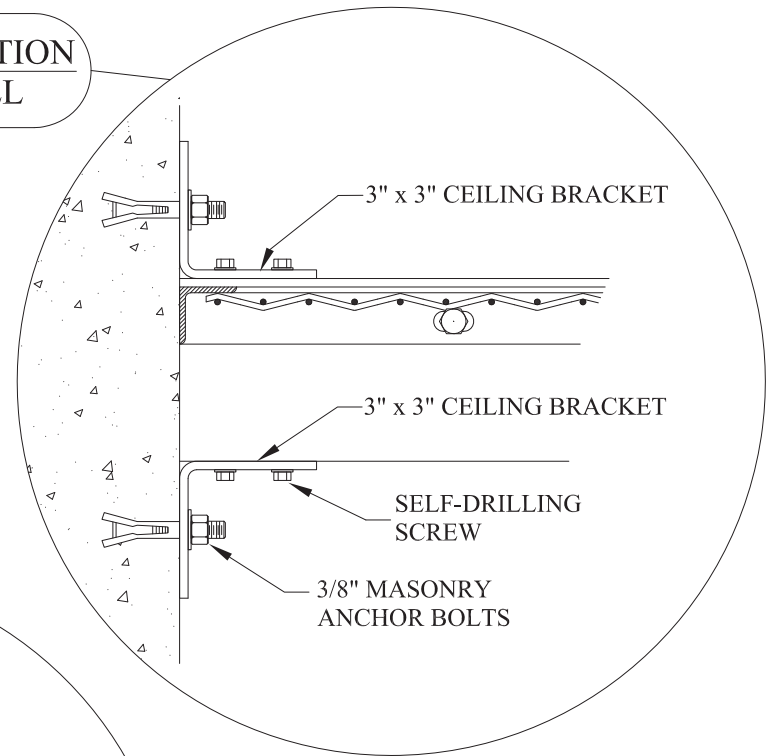

2" X 6" TUBE CONNECTION TO MASONRY WALL

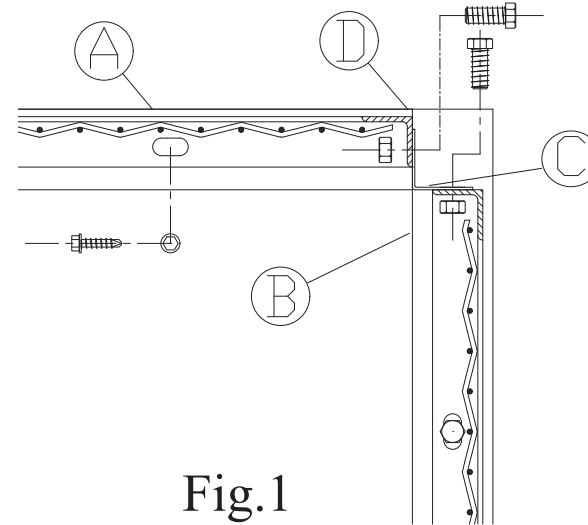
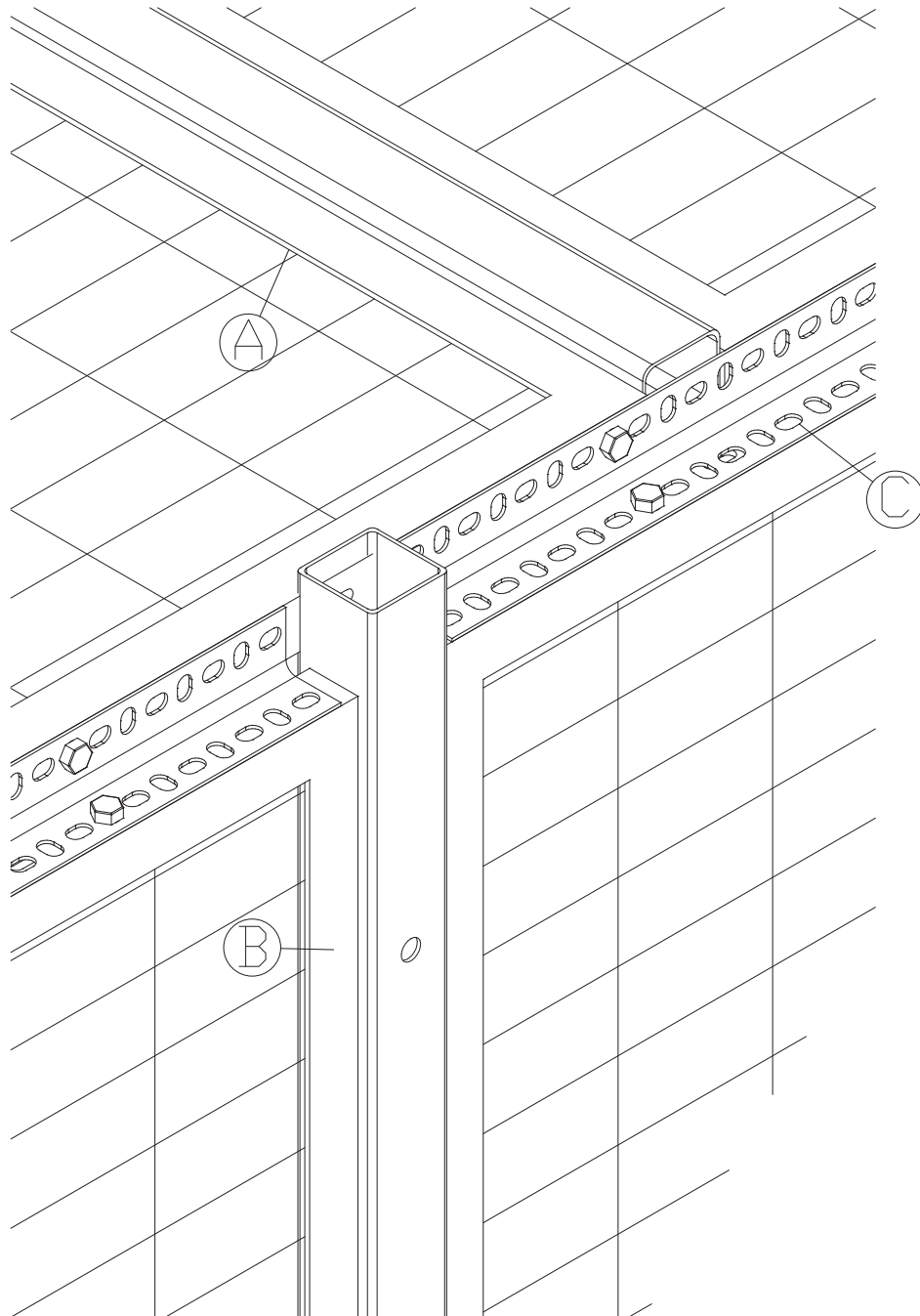
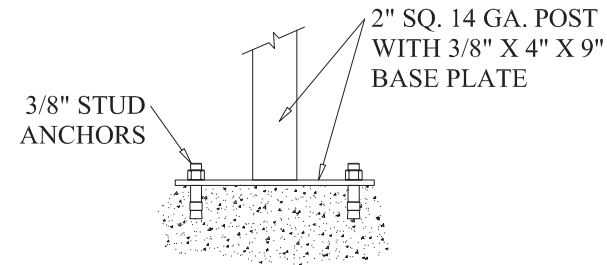
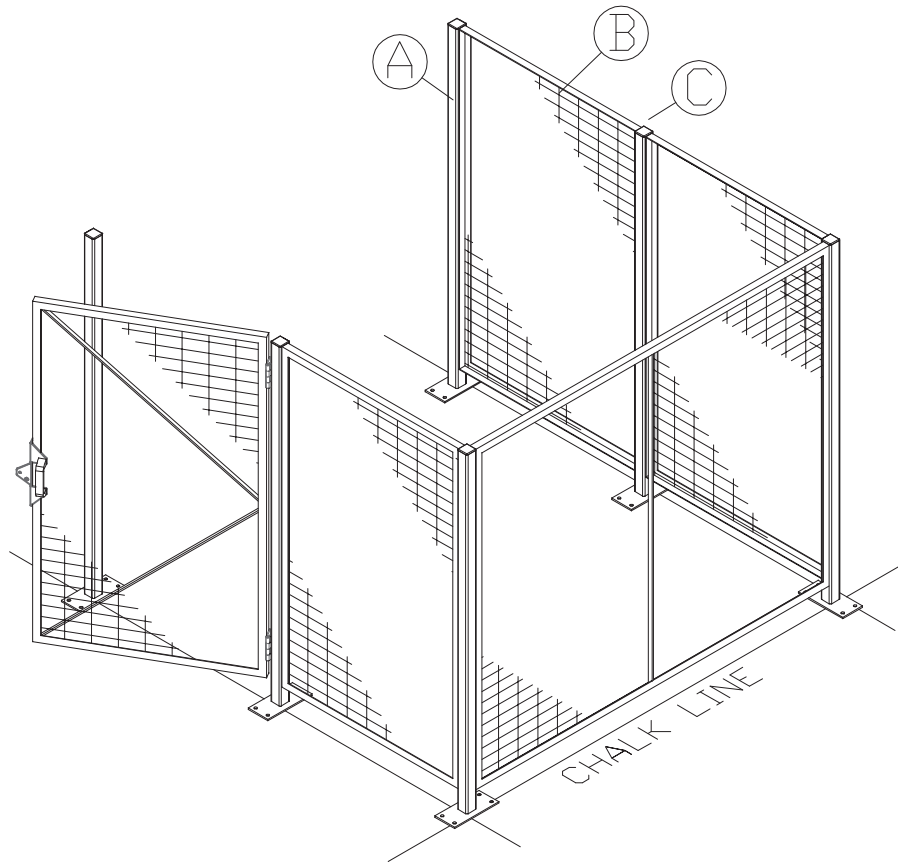

Fig.1

2" x 2" SPACER TUBE

1. Note overall layout of ceiling.
2. Identify location(s) of 2" x 2" spacer tube(s) (A) in ceiling layout.
3. Install at least one of the ceiling panel. Refer to section labeled "Basic Ceiling" of this manual.
4. Align spacer tube (A) with ceiling panel.
 - a. Position panels to eliminate any sag in ceiling before fastening in place.
5. Attach with self-drilling screws per Fig.1.
 - a. Clamp part in place before using self-drilling screws.
6. Install next ceiling panel in layout. Refer to section labeled "Basic Ceiling" of this manual.
7. Repeat step 4 as listed above.



TYPICAL POST
TO FLOOR CONNECTION

Fig. 1

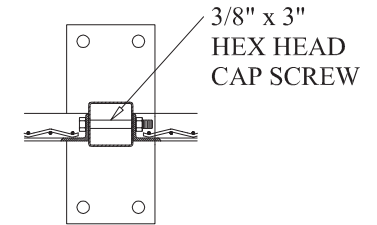

TYPICAL RUN
POST CONNECTION

Fig. 2

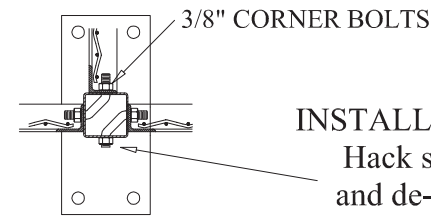

TYPICAL CORNER &
TEE POST CONNECTION

Fig. 3

INSTALLER NOTE
Hack saw off
and de-burr all
protruding threads

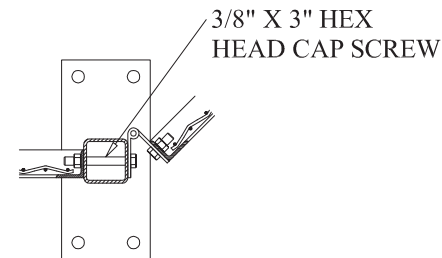

ADJUSTABLE HINGE
CONNECTION

Fig. 4

PHYSICAL BARRIER 5'-3 1/4" HEIGHT PANEL & POST INSTALLATION

1. Use a chalk line to outline the partition layout on the floor.
 - a. Out to out dimensions shown on drawing are to face side of posts.
 - b. Post base plates project beyond outline of partition.
2. Lag end post (A) to floor per Fig. 1 using anchors provided.
3. Mount panel (B) to post (A)
 - a. Per Fig. 2 for straight run using two 3/8" x 3" straight bolts, or
 - b. Per Fig. 3 for 90 degree corner using two 3/8" corner bolts, or
 - c. Per Fig 4 for adjustable angle, mount hinge with 3/8" x 3" straight bolts or
 - d. If mounting directly to building wall skip this step.
 - e. **Note: Panels install horizontally; 2" mesh opening parallel with floor.**
4. Attach opposite end of panel (B) to second post (C)
 - a. Per Fig 2 for run post, or
 - b. Per Fig 3 for corner post.
5. Lag post to floor using anchors provided

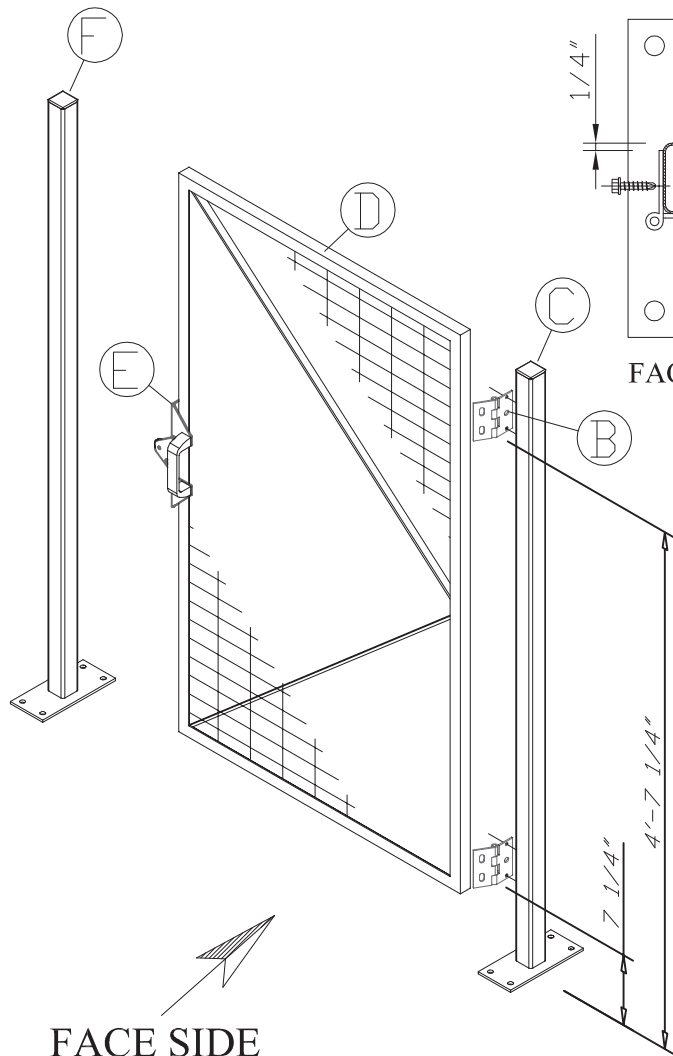

FACE SIDE

Stock Height Barrier Door Shown
Dimensions Shown are From Floor
to Bottom of Part

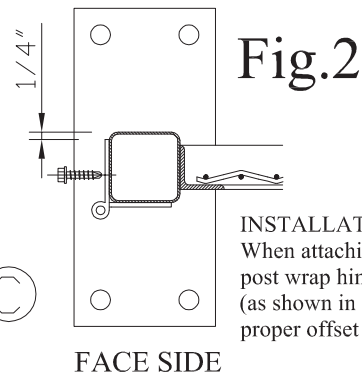

Fig.2

INSTALLATION TIP:
When attaching hinge to door
post wrap hinge around post
(as shown in drawing) to set
proper offset alignment

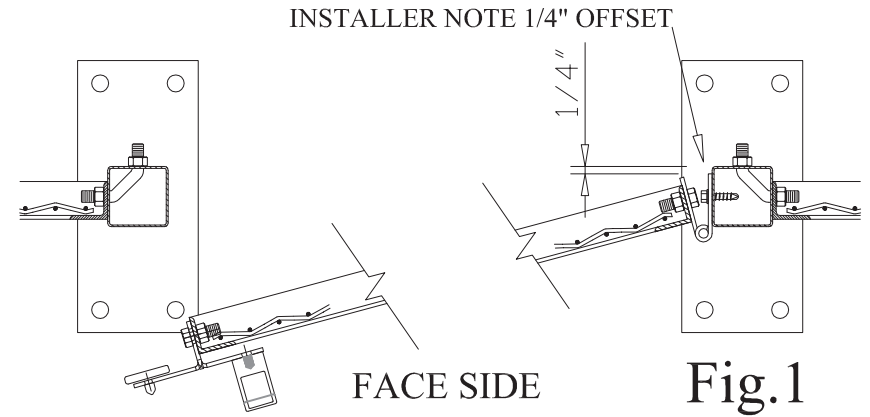

Fig.1

INSTALLER NOTES:

1. Component parts attach using self-drilling screws. Use variable speed screw gun with adjustable clutch or depth locating nose piece. Use care not to over tighten and strip threads. **DO NOT USE IMPACT TYPE GUNS.** Securely clamp part in place before attaching with self drilling screws.
2. The dimensions shown on this page are for standard physical barrier hinge doors 5'-0" tall with a sweep space of 1'-0". Use worksheet on page 29 to calculate component locations for non-standard door opening heights or sweep spaces.
3. Partition wall should be set up and anchored to floor, with posts plumb before attempting to install doors.

Physical Barrier Hinge Door Outside Swing

1. Check opening width at floor, and anchor posts to floor.
 - a. Check that posts are plumb and opening is square.
2. Attach hinges (B) to door post (C) using two self drilling screws per hinge.
 - a. Note hinge placement offset detailed in Fig 1 and install tip Fig 2.
 - b. If necessary, remove two 3/8" x 3" panel mounting bolts and replace with corner bolts. Cut off and file smooth any protruding bolt threads.
3. Attach door panel (D) to hinges with two 3/8" x 1" bolts and nuts per hinge.
 - a. Set desired sweep space (3 1/4" for stock doors).
4. Attach handle bracket (E) to door panel (D) using two 3/8" x 1" bolts.
 - a. Attached handle to bracket (E) with two 1/4"-20 x 1/2" button head screw
 - b. Attached magnet to bracket with M6-1.0 Acorn nut and washer.
5. Check operation of door, adjust as needed.

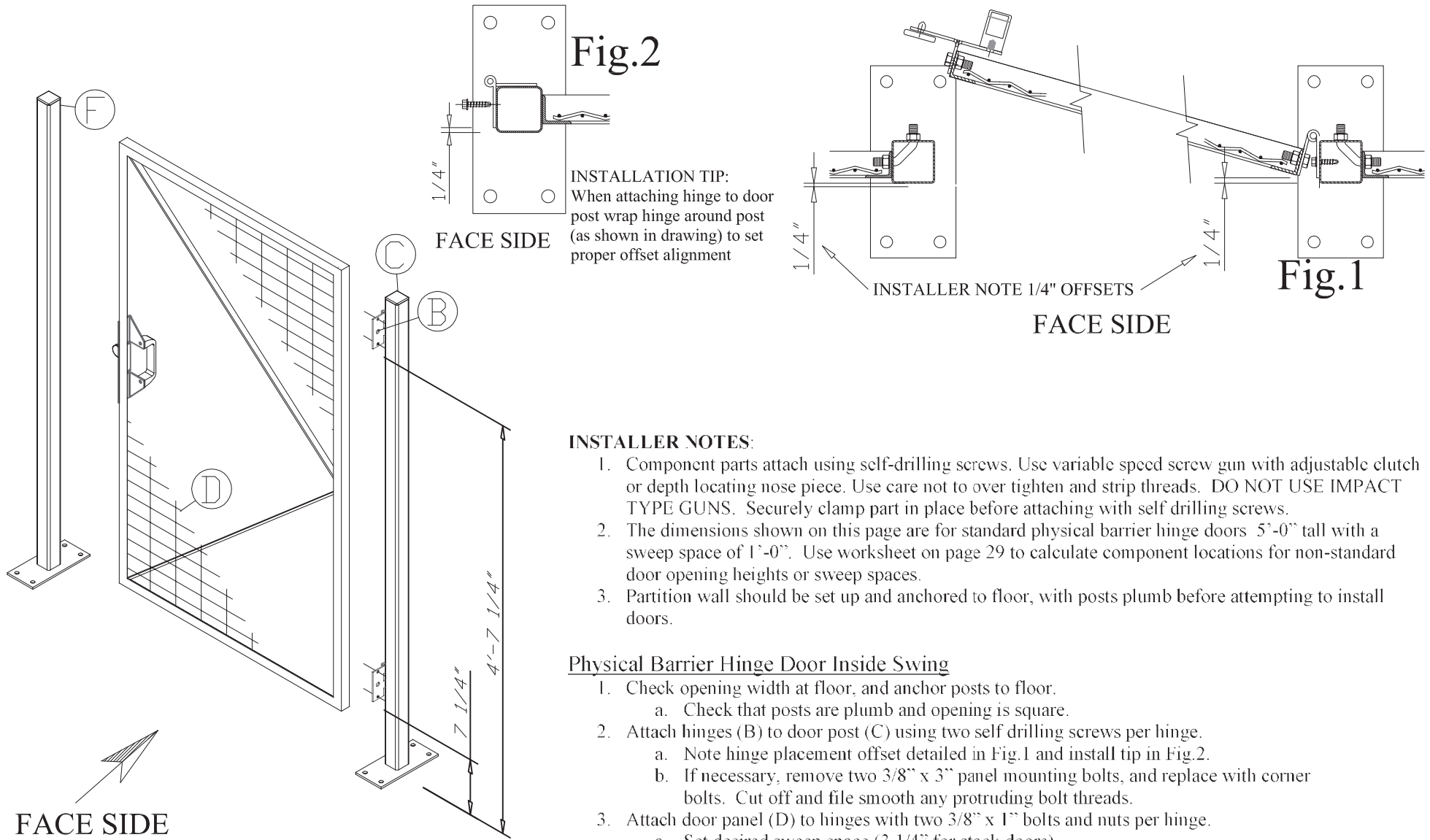

INSTALLER NOTES:

- Component parts attach using self-drilling screws. Use variable speed screw gun with adjustable clutch or depth locating nose piece. Use care not to over tighten and strip threads. **DO NOT USE IMPACT TYPE GUNS.** Securely clamp part in place before attaching with self drilling screws.
- The dimensions shown on this page are for standard physical barrier hinge doors 5'-0" tall with a sweep space of 1'-0". Use worksheet on page 29 to calculate component locations for non-standard door opening heights or sweep spaces.
- Partition wall should be set up and anchored to floor, with posts plumb before attempting to install doors.

Physical Barrier Hinge Door Inside Swing

- Check opening width at floor, and anchor posts to floor.
 - Check that posts are plumb and opening is square.
- Attach hinges (B) to door post (C) using two self drilling screws per hinge.
 - Note hinge placement offset detailed in Fig.1 and install tip in Fig.2.
 - If necessary, remove two 3/8" x 3" panel mounting bolts, and replace with corner bolts. Cut off and file smooth any protruding bolt threads.
- Attach door panel (D) to hinges with two 3/8" x 1" bolts and nuts per hinge.
 - Set desired sweep space (3 1/4" for stock doors).
- Attach handle bracket (E) to door panel (D) using two 3/8" x 1" bolts.
 - Attached handle to bracket (E) with two 1/4"-20 x 1/2" button head screw
 - Attached magnet to bracket with M6-1.0 Acorn nut and washer.
- Check operation of door, adjust as needed.

Stock Height Barrier Door Shown
Dimensions Shown are From Floor
to Bottom of Part

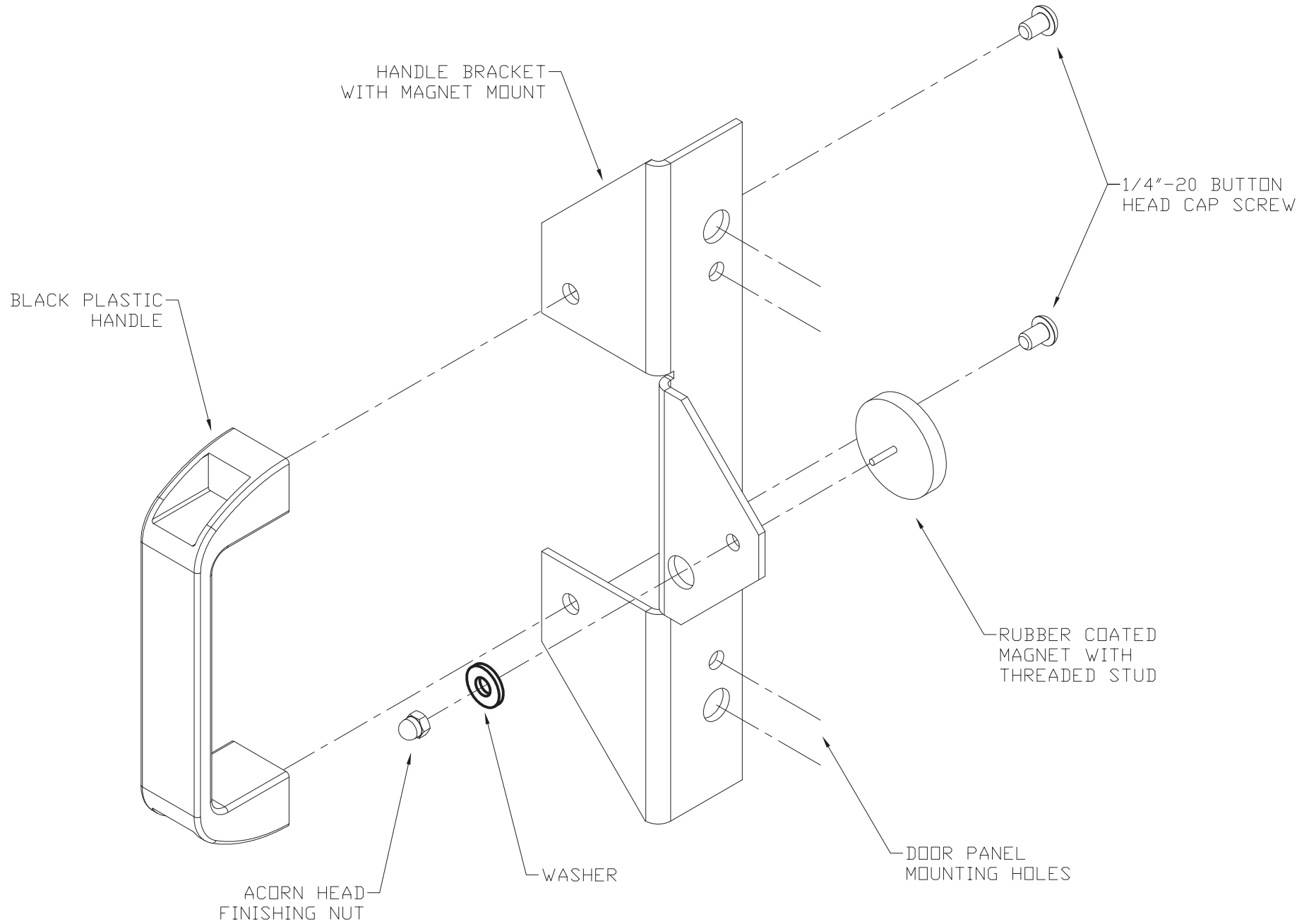
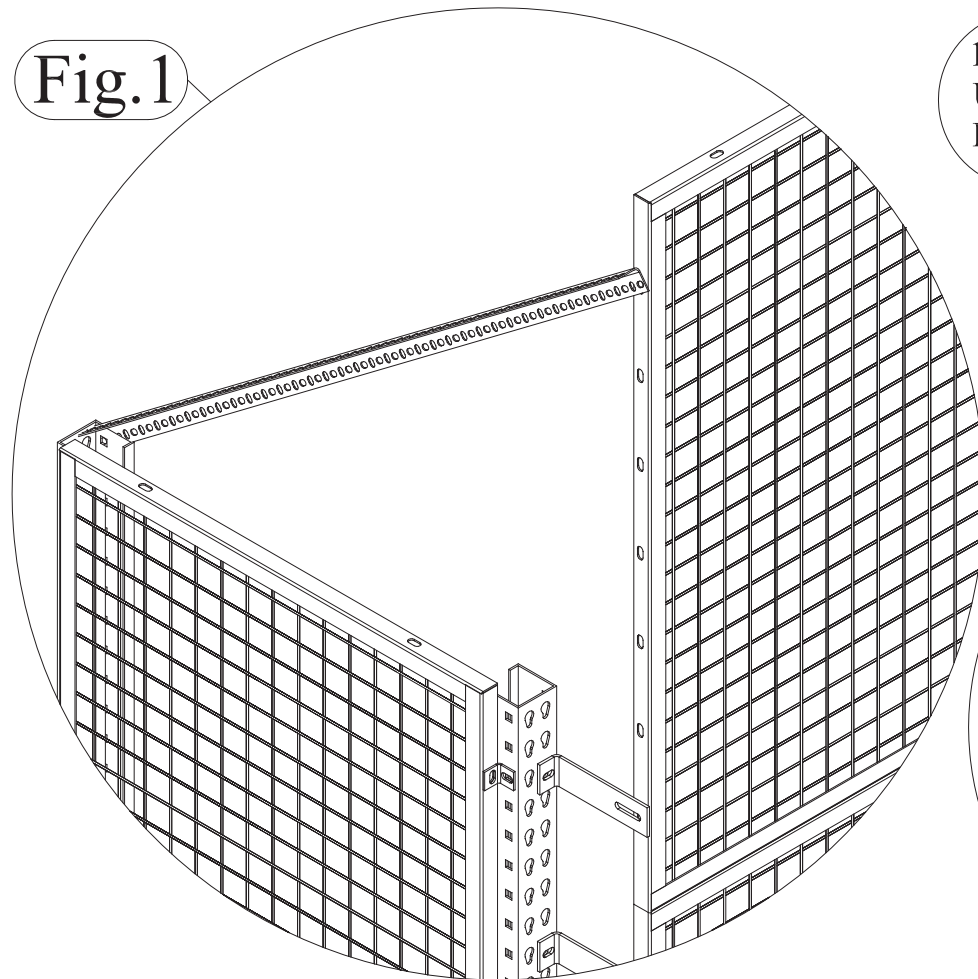
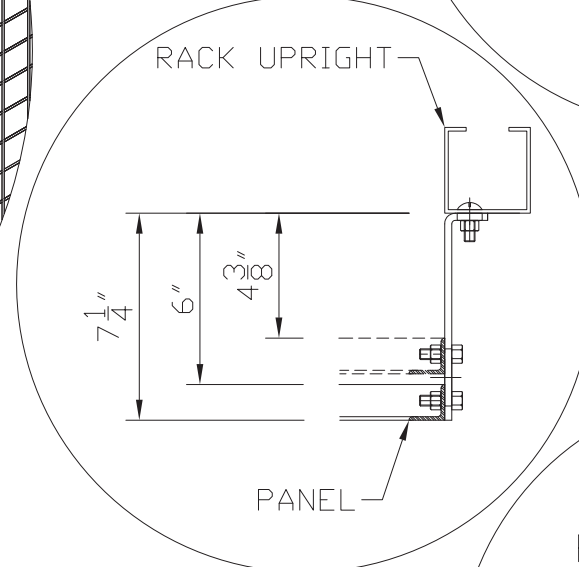
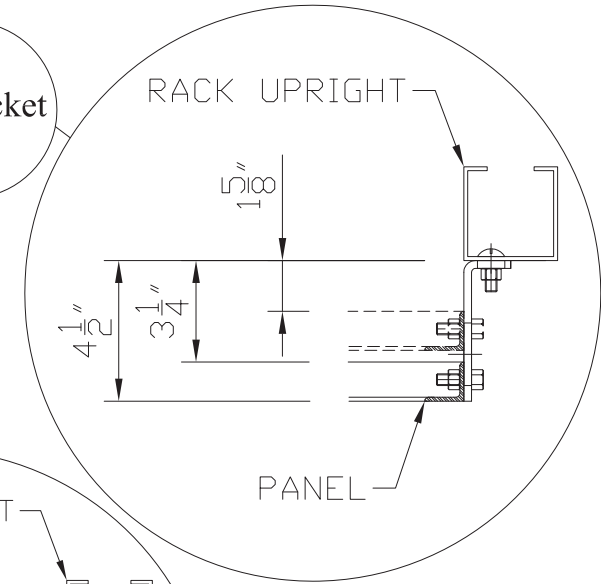

Fig. 1



1 5/8" to 3 1/4" Offset
Uses 4 1/2" x 1 1/2" Bracket
Part# OPANCL412112



4 3/8" to 6" Offset
Uses 7 1/4" x 1 1/2" Bracket
Part# OPANCL714112

Flush Mount
Uses 1 1/4" x 1/4" Bracket
Part# OPANCL114182H

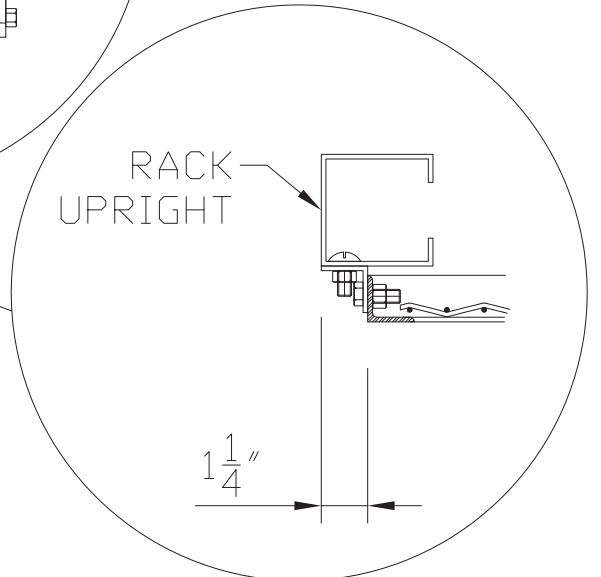

INSTALLER NOTES

1. Provided mounting hardware may not be appropriate for all types of rack. Installer may need to acquire additional or other type fasteners.
2. It is installer's responsibility to securely install brackets and panels to rack structure.

Rack Back® Panels

1. Note slotted hole location on end of panels. Attach mounting bracket to rack uprights corresponding to holes on end of panels.
2. Lift panels into place between mounting brackets, and secure with 3/8" x 1" bolt.
3. Align panels with those above or below to form wall and connect horizontal members of panels with 3/8" x 1" bolts.
4. Panels rising above rack structure may be secured with slotted angle. See Fig. 1.

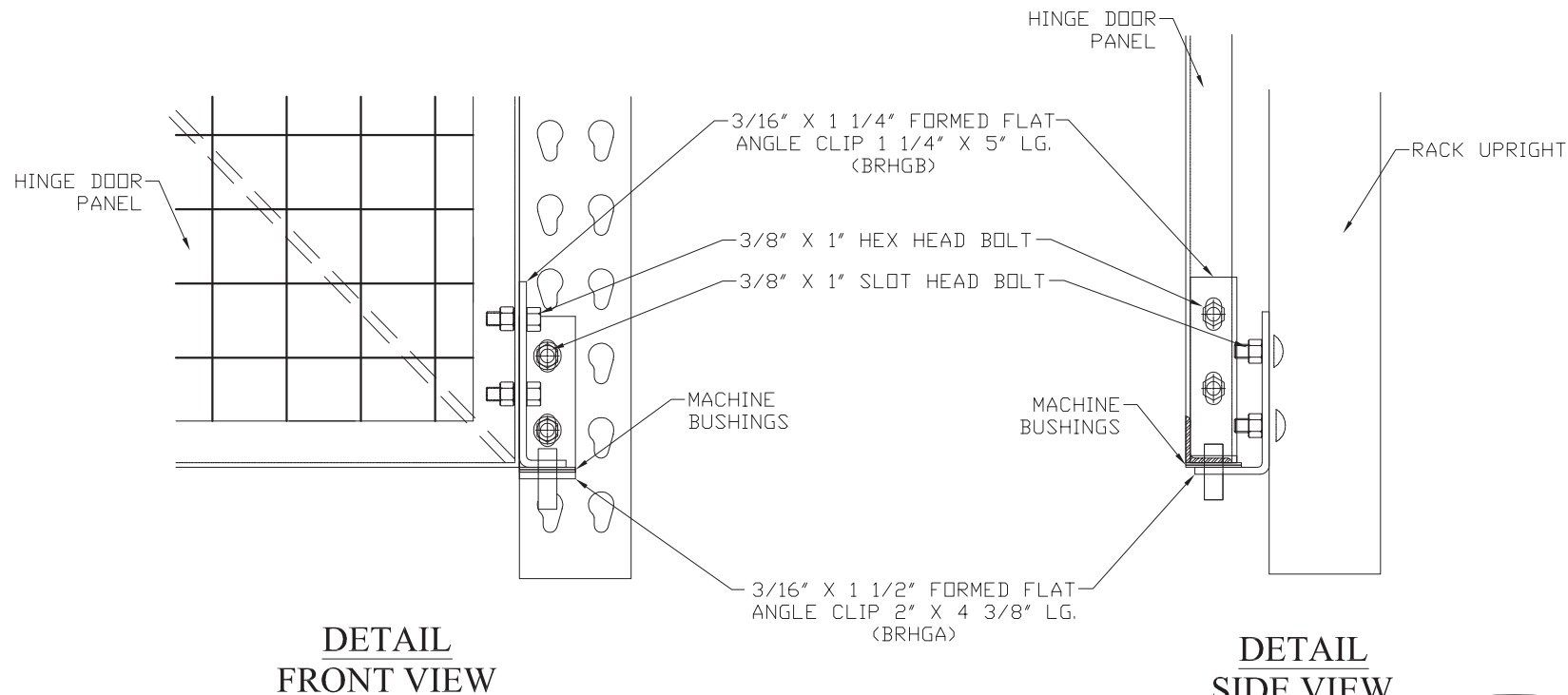

INSTALLER NOTES

1. Provided mounting hardware may not be appropriate for all types of rack. Installer may need to acquire additional or other type fasteners.

Rack Back® Hinge Gates

1. Locate gate hinge brackets (brackets with pins attached) and machine bushings.
2. Use 3/8" x 1" bolts to install gate hinge bracket on outside corners of gate panel (pins should be pointing in opposite directions after installed).
3. Install only lower receiver bracket (bracket with no pin) on rack upright at desired sweep space.
4. Place bushing over hinge pin, and lift gate into place so that lower hinge pin fits into lower receiver bracket.
5. Place upper receiver bracket over hinge pin and fasten receiver to rack.
 - a. Check that top of gate is level, and overall operation of gate.
6. If double hinge gate, repeat procedure for opposite door panel.
 - a. Use same sweep space dimension as first panel.
 - b. Check that gap between doors is sufficient for operation of doors and lock device, if not adjust mount brackets appropriately.
7. If single hinge gate, align padlock lug with door lug and attach to rack.

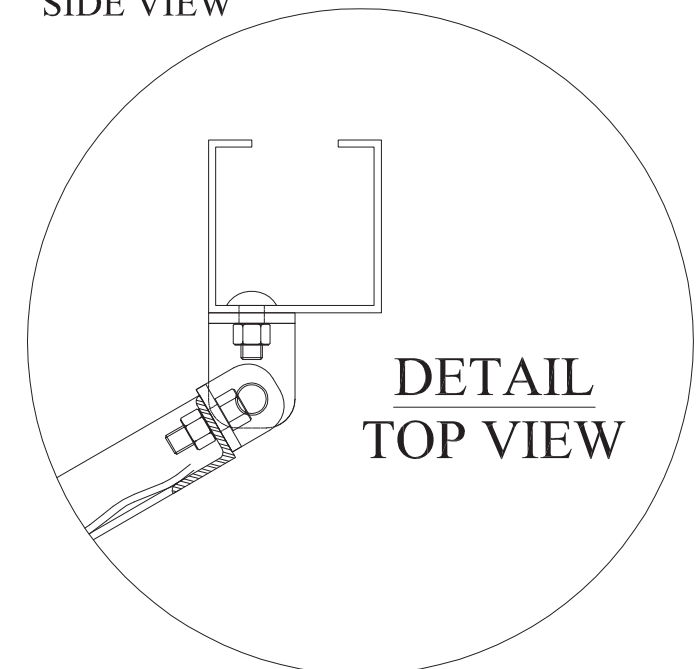

NON-STOCK COMPONENT LOCATION WORK SHEET

All locations are from floor to bottom of component

Fill in blanks with appropriate Dimensions before starting calculations

Sweep Space _____
Door Leaf Height _____
Center Line of Door _____ (Divide Door Leaf Height in Half)
Center Line of Tongue Hole in Door Leaf _____
Bottom Door Leaf Height _____ (Dutch Door Only)
Top Door Leaf Height _____ (Dutch Door Only)

Hinge Door Components

Bottom Hinge Location : Sweep Space + 4" = _____
Center Hinge Location : (Sweep Space + Center line of Door) then subtract 2" = _____
Top Hinge Location : (Door Height + Sweep Space) then subtract 8" = _____
Receiver Location : (Center Line of Tongue Hole in Door Leaf + Sweep Space) then Subtract 3 1/2" = _____
Angle Pick Plate : (Center Line of Tongue Hole in Door Leaf + Sweep Space) then Subtract 10" = _____ (Inside Swing Only)

Dutch Door Components

Bottom Hinge Bottom Leaf : Sweep Space + 4" = _____
Top Hinge Bottom Leaf : (Sweep Space + Bottom Door Leaf Height) then subtract 8" = _____
Bottom Hinge Top Leaf : Bottom Door Leaf Height + Sweep Space + 5/8" + 4" = _____
Top Hinge Top Leaf : (Bottom Door Leaf Height + Sweep Space + 5/8" + Top Door Leaf Height) then subtract 8" = _____
Receiver Location : (Center Line of Tongue Hole in Door Leaf + Sweep Space) Subtract 3 1/2" = _____

Thanks for using
WireCrafters
woven wire partitions.

Tool Cribs • Storage Lockers • Machine Guards • Mezzanine Rails • Pallet Rack Backs • Security Enclosures

WireCrafters

We appreciate your business, and hope to work with you on future projects. A significant effort went into creating this instruction booklet and we are interested in your comments regarding it. Please answer the questions below, tear off this page, and fax it to us at 502-361-3857, or fold on the dotted lines, tape shut, and drop in the mail. We welcome your suggestions and observations.

Drawing or B/L Number _____ Date Installed _____

Did you find any of the instructions confusing? If so which one(s) and why. _____

Generally, the instructions are (circle one): Too detailed About right Too general

Did you encounter any assembly problems? If so please describe. _____

Did the product arrive in good condition? _____

Are you satisfied with the product? If not please explain. _____

Other Comments _____
