

Bike Stacker Installation Instructions

WireCrafters

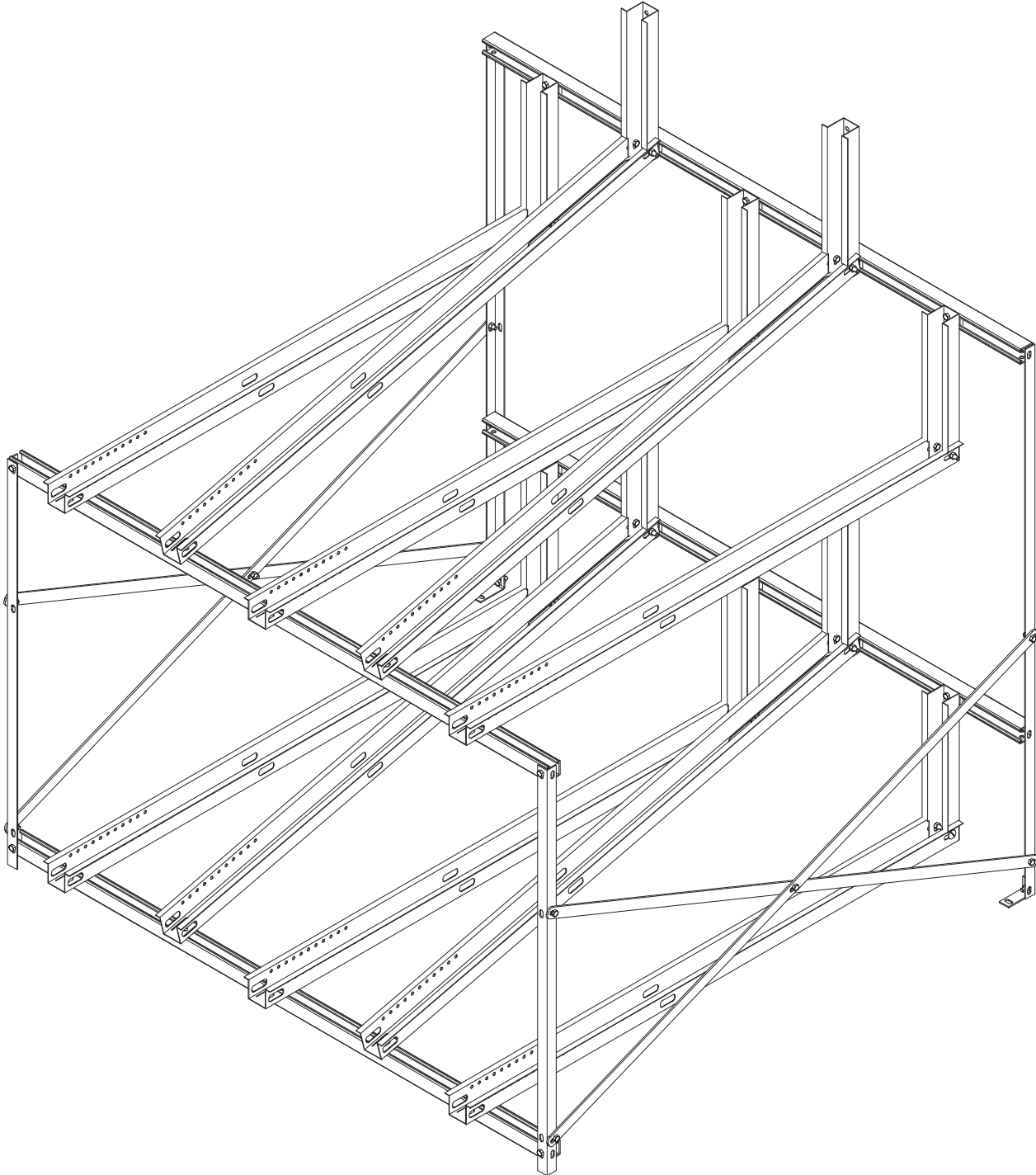

We're Here To Help
1-800-626-1816

WireCrafters

Bike Stacker

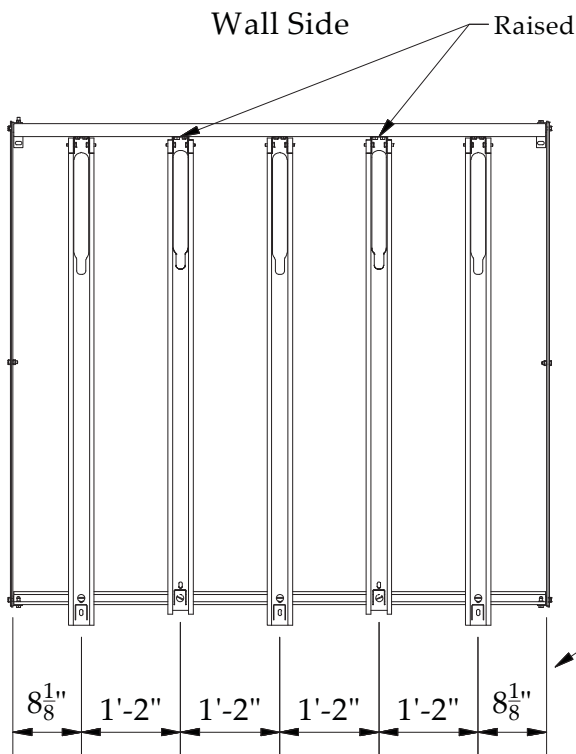

Top View

Ten bicycles stored in 6' double tiered rack shown. Other configurations may be based on this layout.

Tools needed:

- 3/8" socket & ratchet
- 3/8" crescent wrench
- pliers
- hammer drill (if anchor desired)
- 3/8" masonry drill bit

suggested spacing from center of channel to outside of angle leg upright

Note: Trays 2 and 4 are installed in elevated position on upper and lower levels.

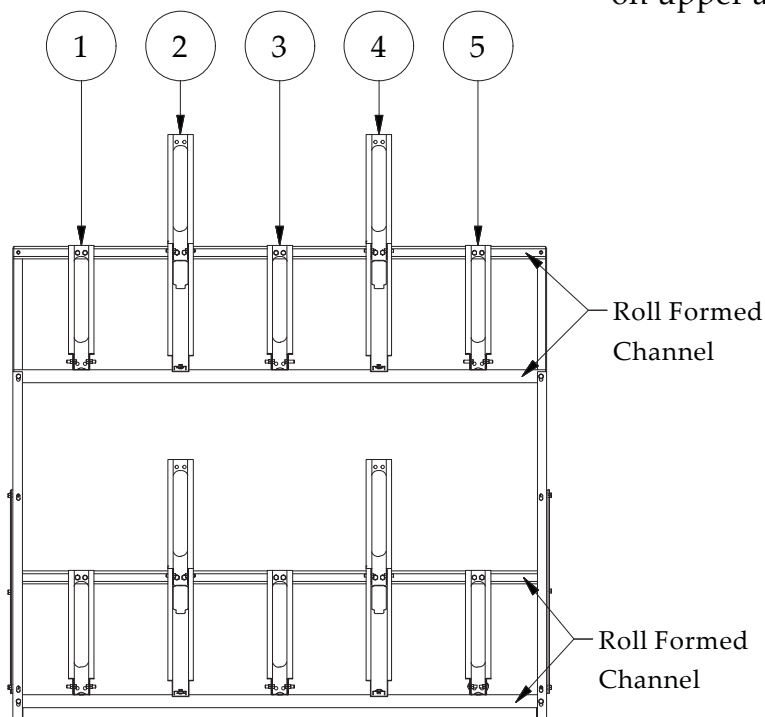

Load Side View

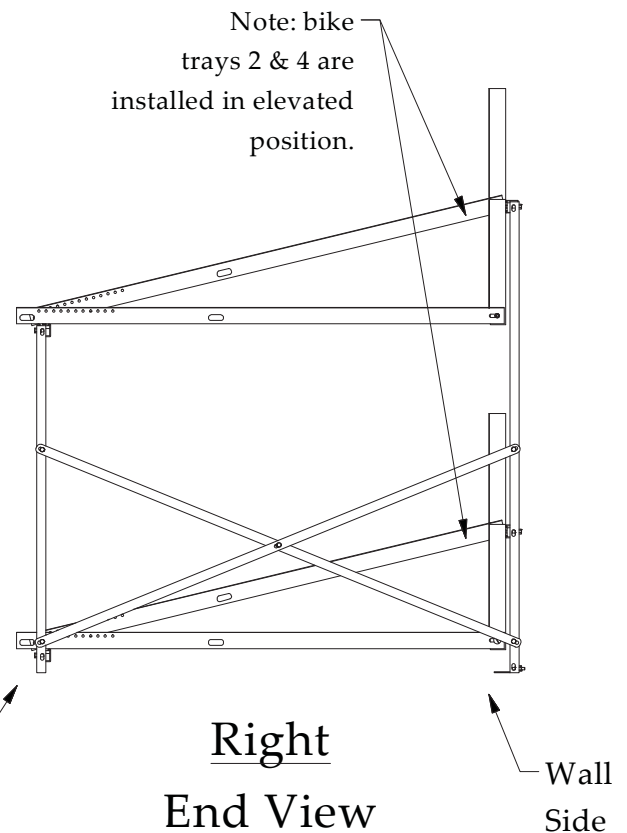

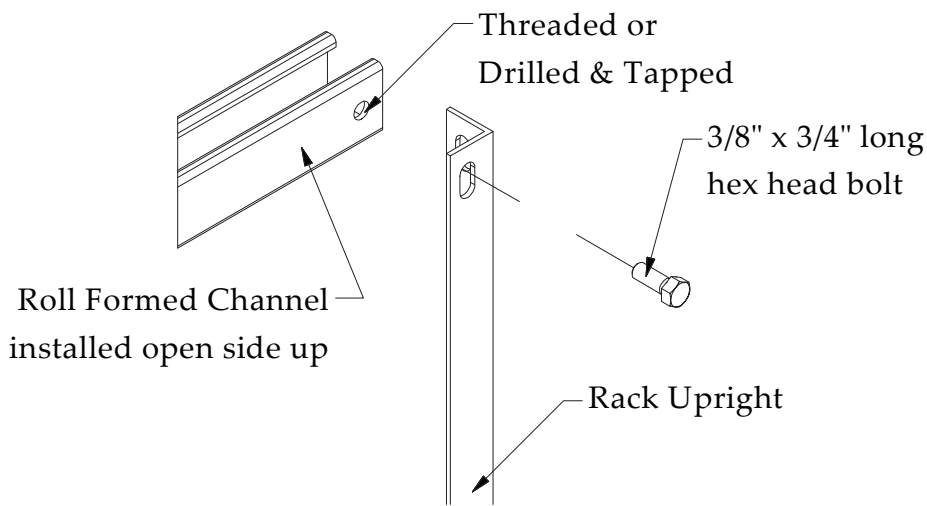

Load Side of Rack

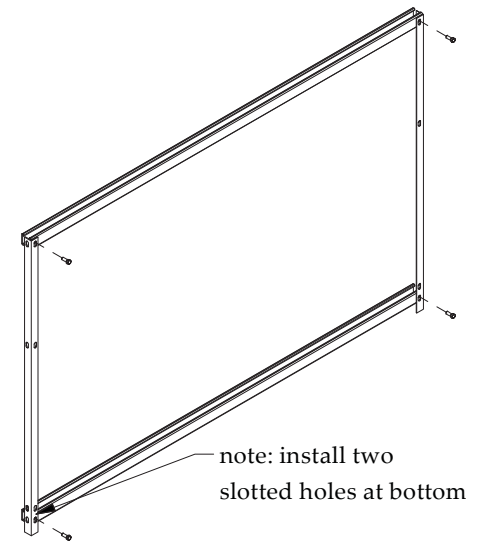

Load End of Rack

1.) Secure two roll formed channels to 3'-11" Load Side Angle Uprights using four 3/8" x 3/4" hex head bolts.

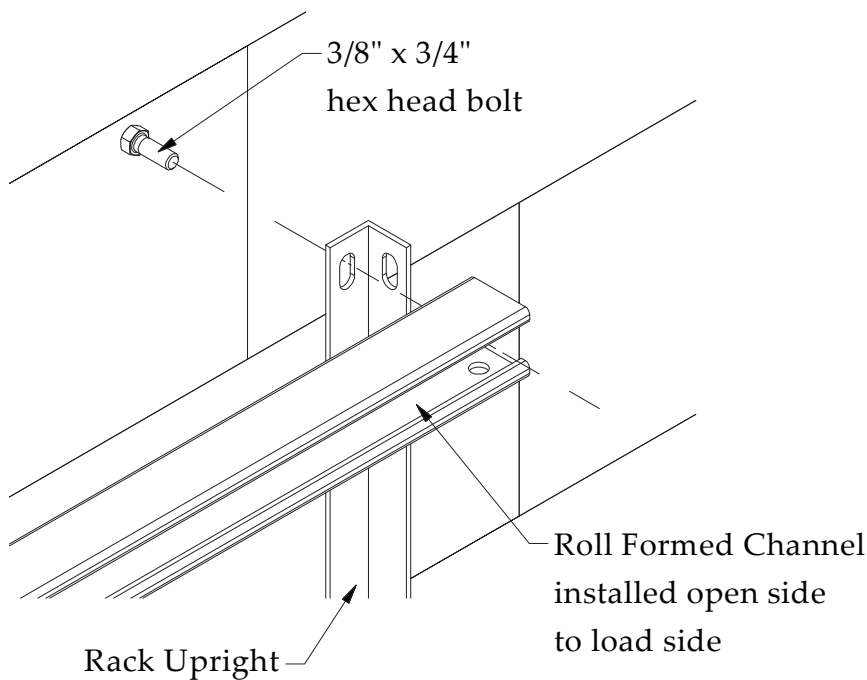

Wall Side of Rack

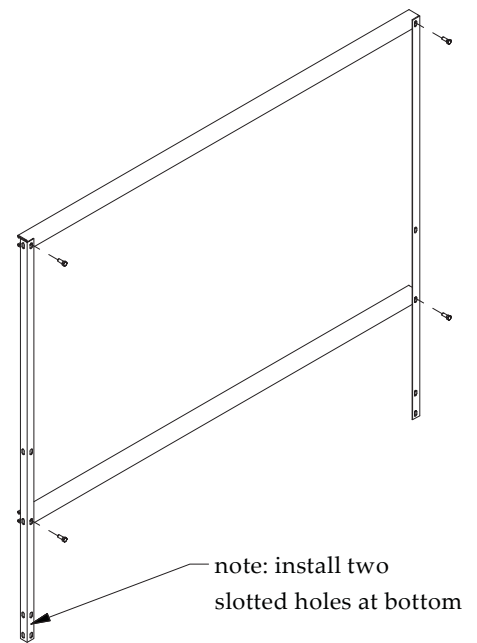

Wall End of Rack

2.) Secure two roll formed channels to 5'-3/4" Wall Side Angle Uprights using four 3/8" x 3/4" hex head bolts.

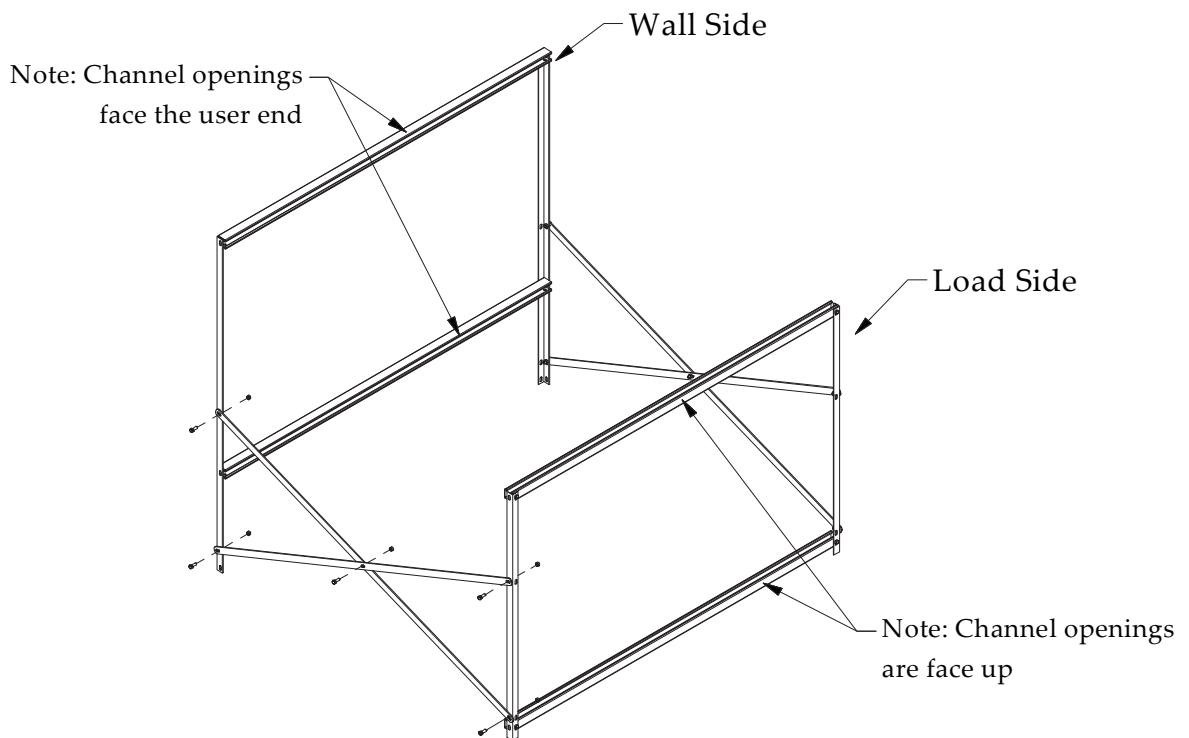
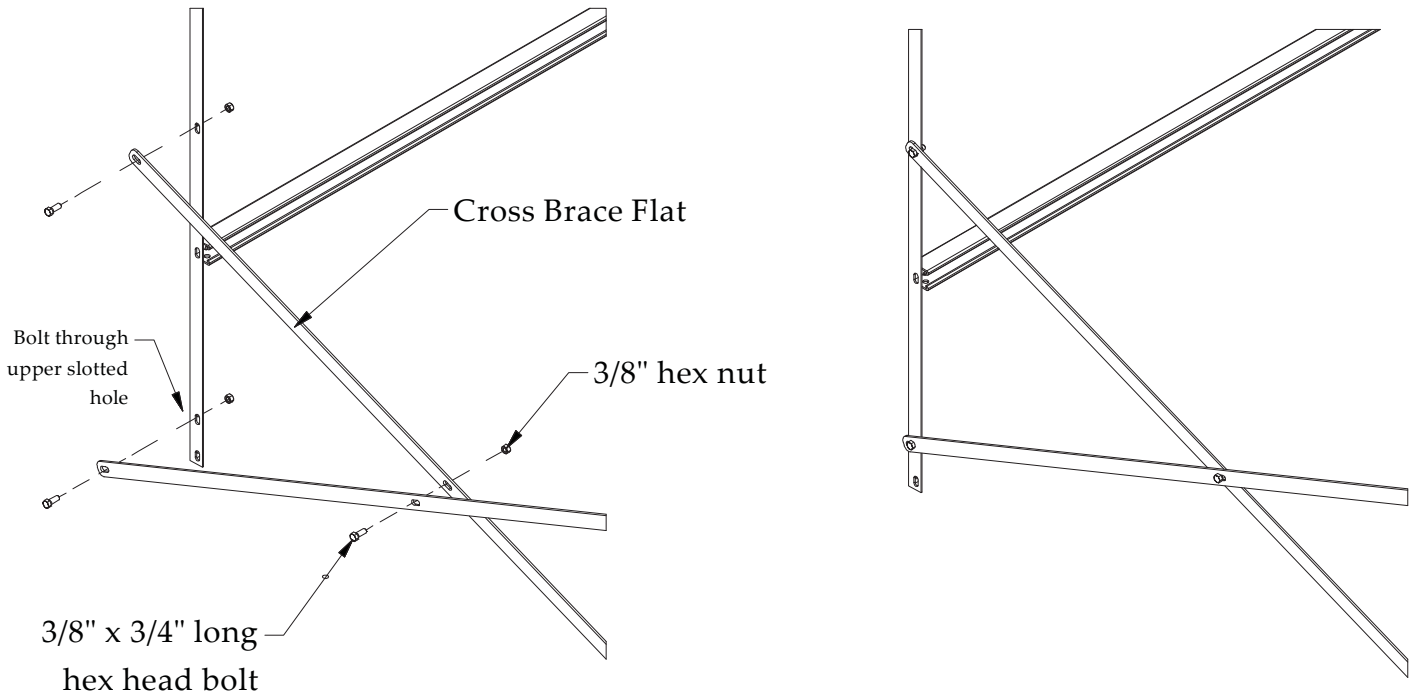

3.) Attach cross brace flats to side of angle uprights using 3/8" x 3/4" hex head bolts and nuts. Be sure to secure unit so that wall end and load end are parallel.

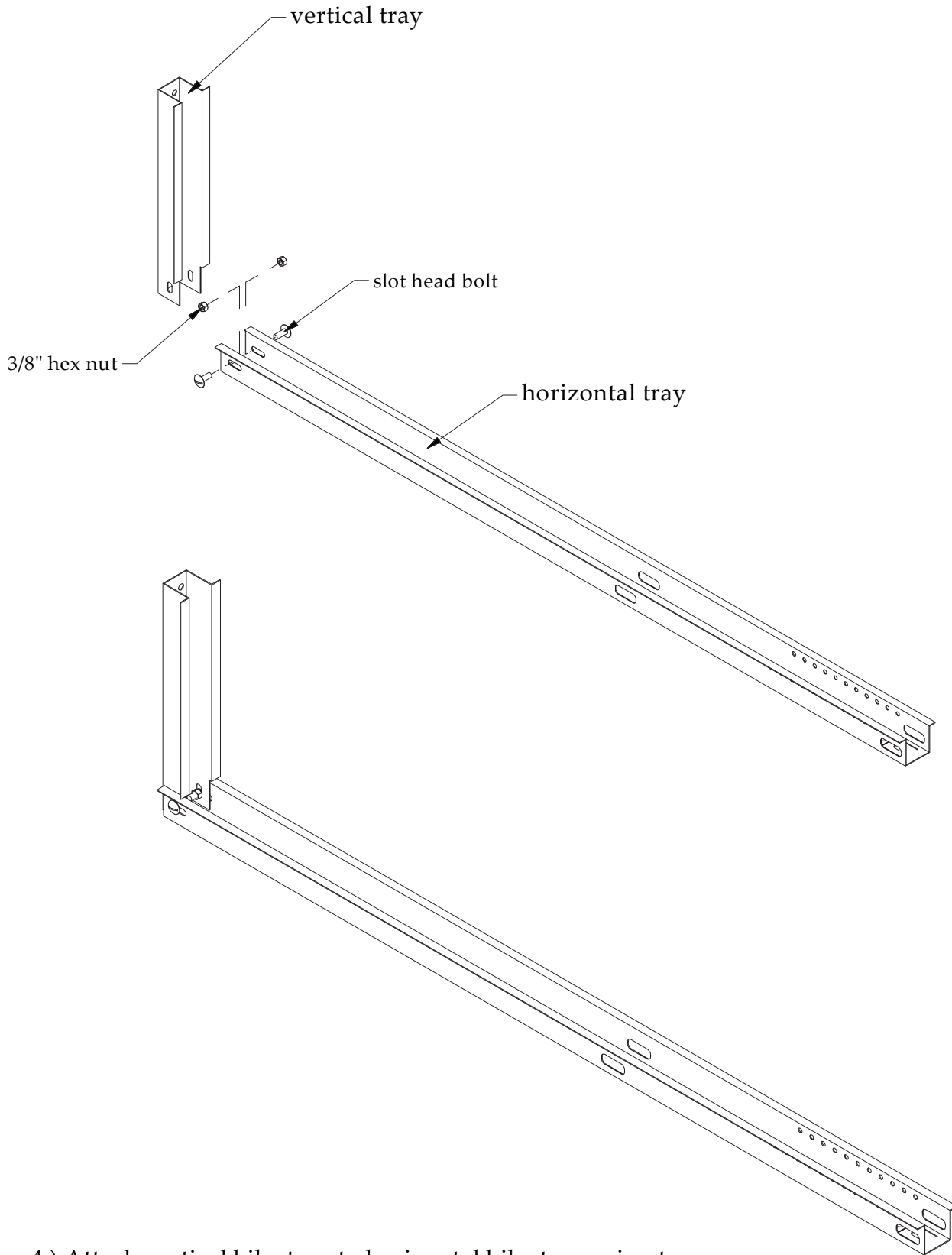

4.) Attach vertical bike tray to horizontal bike tray using two flat head slot head screws and two 3/8" hex nuts. Repeat for all trays.

Flat Tray Installation

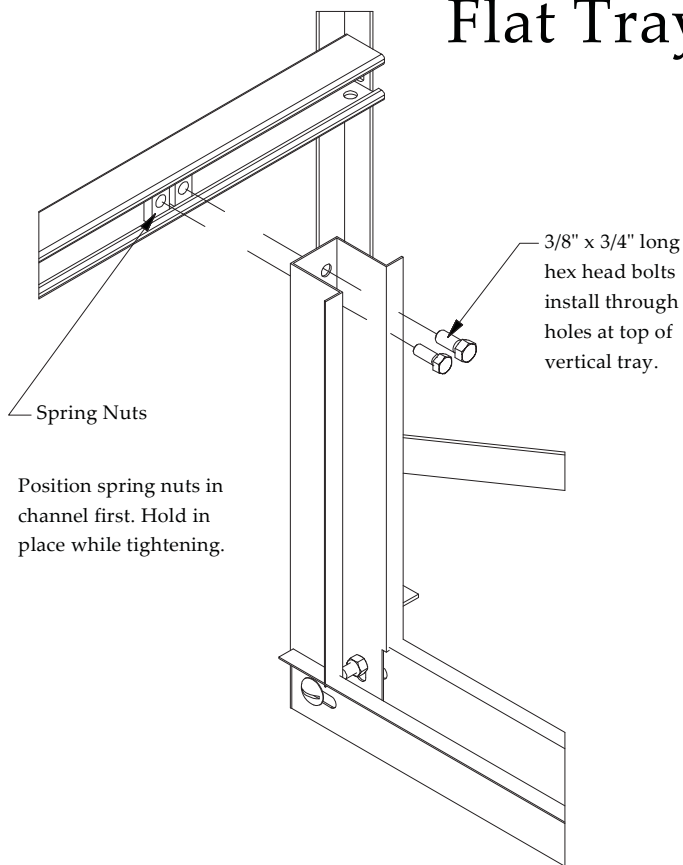

Wall Side

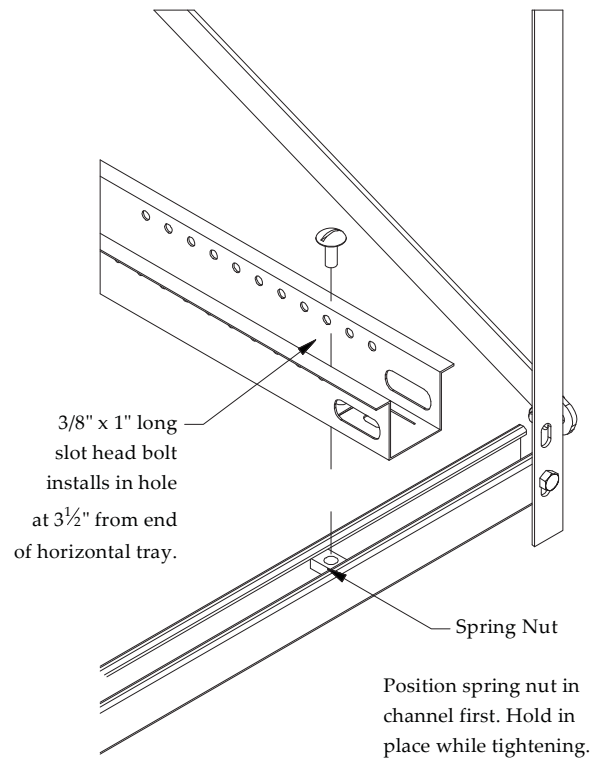

Load Side

5.) Position spring nuts in horizontal channels. Attach vertical end of bike tray to wall side channels using two 3/8" x 3/4" hex head bolts. Attach open end of bike tray to load side of rack with spring nut and one 3/8" x 3/4" flat head. Flat tray should be positioned 8 1/8" (on center) from end of rack.

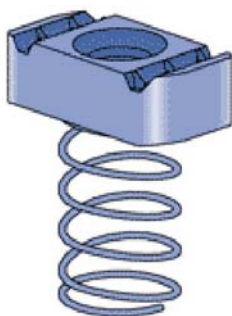
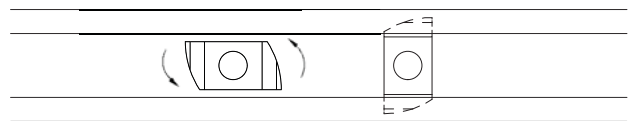

Compress spring nut in channel, then turn so that grooves on spring nut lock into channel legs.

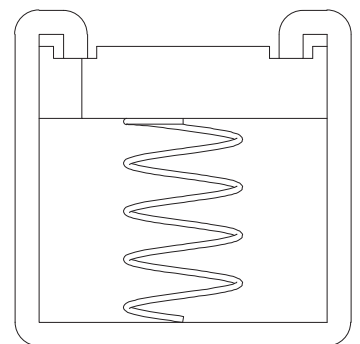

Spring Nut

Raised Tray Installation

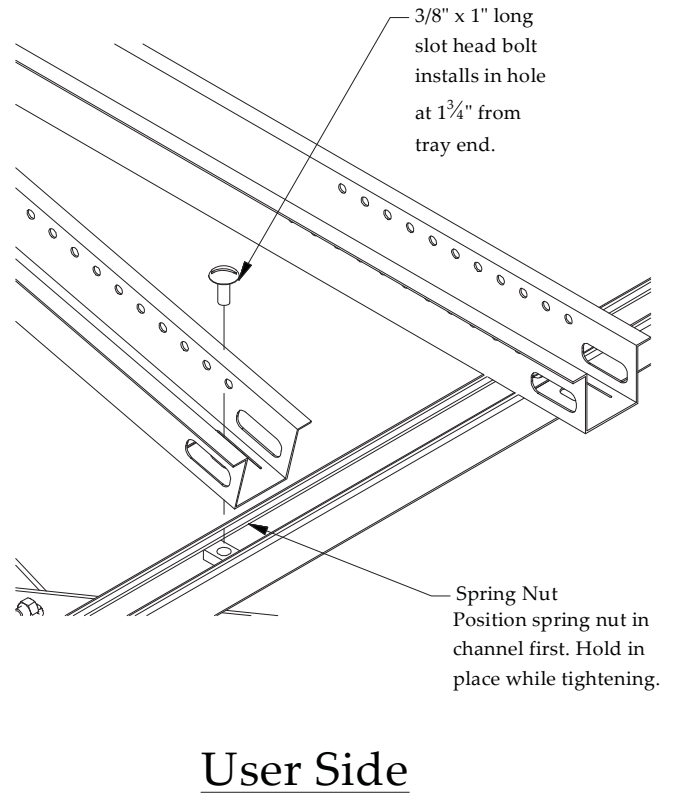
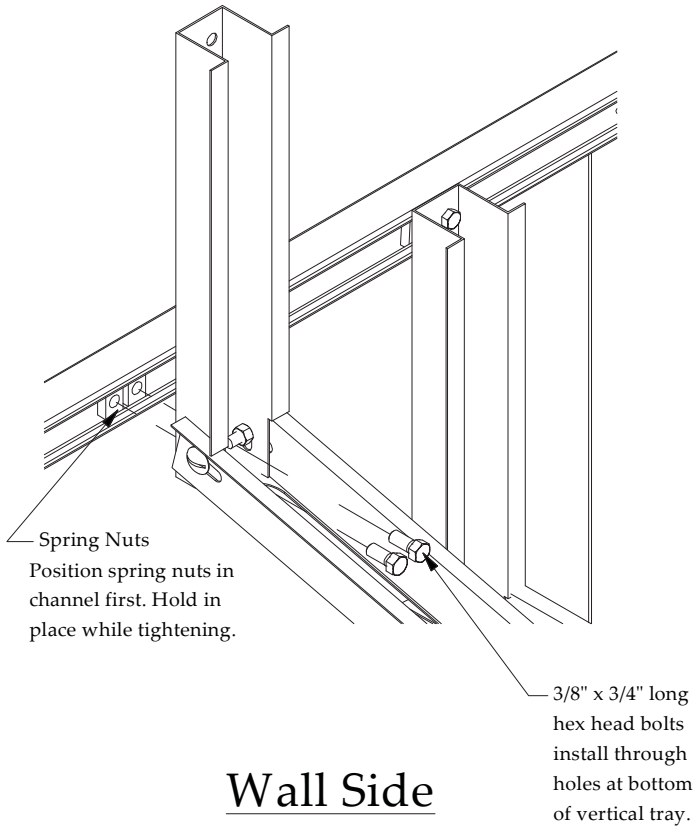

6.) The second bike tray should be installed in the raised position, by attaching the corner of the assembled bike tray to the wall side channel as shown above.

7.) Remaining bike trays should be installed alternating between the horizontal and raised positions. This will allow the handle bars of stored bicycles to clear each other during loading and unloading.

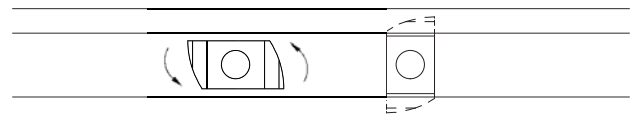
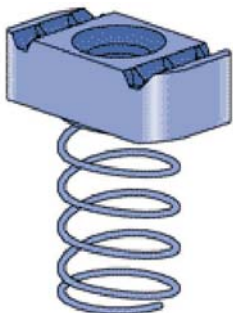

Compress spring nut in channel, then turn so that grooves on spring nut lock into channel legs.

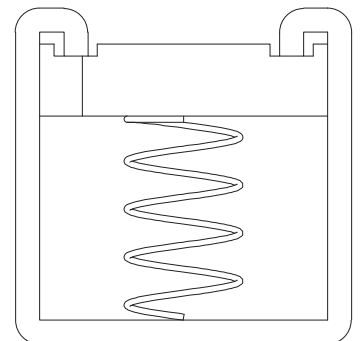

Spring Nut

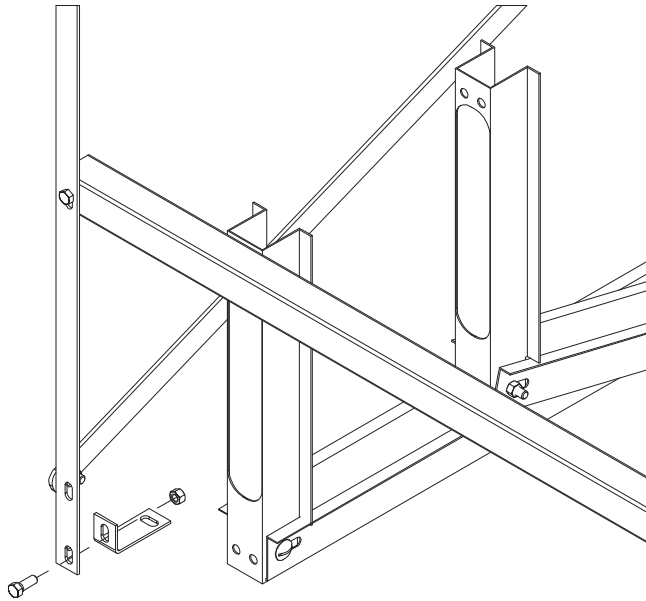

Wall Side of Unit

Attach anchor bracket to wall side angle upright using one 3/8" x 3/4" hex bolt and 3/8" hex nut. Anchor unit to floor using one 3/8" floor anchor (drill 3/8" diameter hole in concrete using hammer drill or other suitable device).

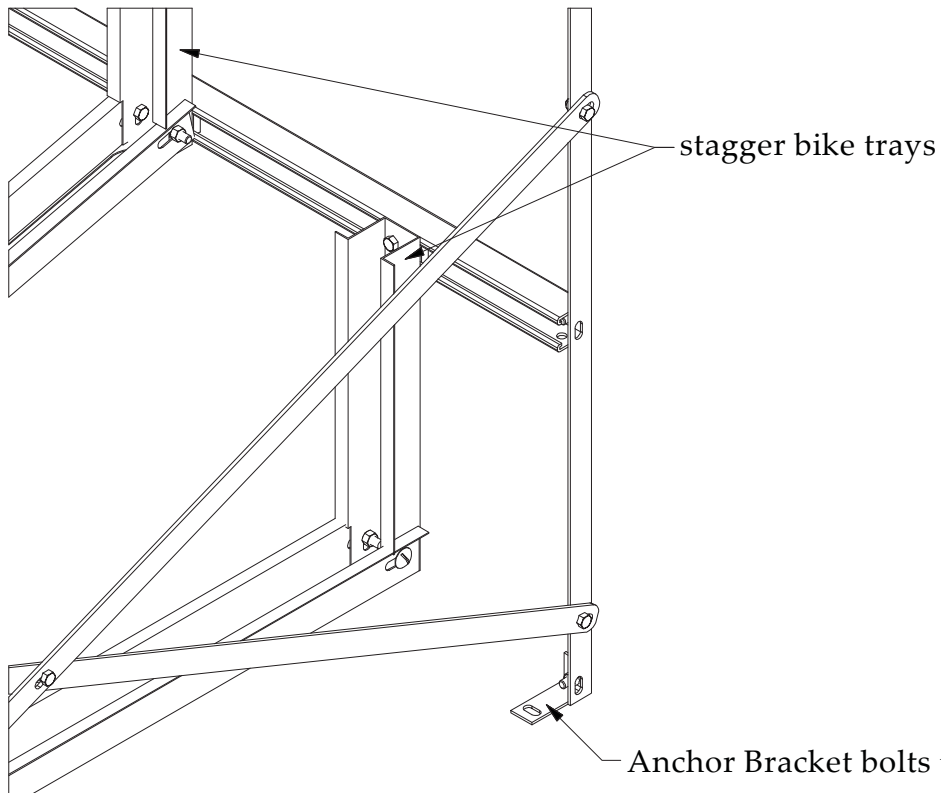

Wall Side of Unit

stagger bike trays

Anchor Bracket bolts to bottom of rack upright for optional floor anchoring