

VM300, VM600 & VM1200 Series Maglock Installation Instructions

PRODUCT INFORMATION

1 Product Specification:

- Holding Force - VM1200 Series: 1200 lbs (544 Kg)
VM600 Series: 600 lbs (272 Kg)
VM300 Series: 300 lbs (136 Kg)
- 12 & 24 volts DC operation (selectable).
Note: Factory default setting is 12VDC.

Product Type:

- Besides unmonitored version, all VM Series locks have either magnetic bond sensor (MBS) or door position switch (DPS) or both.
- For VM1200 and VM600 Series, magnetic bond sensor uses hall effect sensor. For VM300 Series, uses change-over reed switch sensor.
- For VM1200 and VM600 Series, door position sensing uses change-over reed switch sensor.

VM1200 and VM600 Series with MBS:

- For VM1200 and VM600 Series, the LED operation color can be field set. The colors can be reversed simply by reversing the 2 pin plug connection on the PCB.
- There is no LED or DPS available on the VM300 Series
- The factory default setting is as follows:

LED indicator off	(No power to the magnet)
LED indicator red	(Power on magnet, door open)
LED indicator green	(Power on magnet, door closed)

- *Note:* where the Maglock has both MBS and DPS, the LED indicates as per the MBS model.

Product Dimensions (L x W x H):

- VM1200 Series - 10-1/2" x 2-7/8" x 1-9/16" [266mm x 72mm x 40mm]
- VM600 Series - 9-3/8" x 1-7/8" x 1-1/6" [238mm x 48mm x 26.5mm]
- VM300 Series - 6-11/16" x 1-5/8" x 7/8" [170mm x 41.4mm x 22.8mm]

PRODUCT INSTALLATION AND WIRING

2 Installation Requirements:

- Adjust onboard PCB shunt settings for correct operating voltage prior to applying power to the EML.

For 12 volts two shunts must be installed:
- First shunt joining pins 1 & 2
- Second shunt joining pins 3 & 4.

For a 24 volt system only one shunt is required, joining pins 2 & 3.

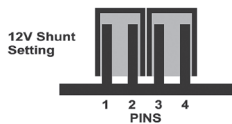

Product Power Input Wiring:

For VM1200 and VM600 Series, this can be wired directly onto the PCB terminal block that has label + and -.

For VM300 Series, these are flying leads. Red wire is + and black wire is -.
(NO NEED TO REMOVE COVER PLATE FOR VM300)

Wiring for models with MBS:

For VM1200 and VM600 Series, the signal is given out from SPDT relay. Wiring can be done through PCB 3-block terminal labels NC, COM, and NO.

For VM300 series has 3 flying leads. Black wire is COM, green wire is NO and white wire is NC.

Wiring for models with DPS:

For VM1200 Series, the signal is given out from the 3 block terminal (NC, COM, NO) that is labeled Reed on the PCB. For VM600 Series, there are 3 flying leads. Black wire is COM, green wire is NO and white wire is NC.

STANDARD MOUNTING METHOD

- 3 • Use the supplied template to determine the correct location and size of mounting holes for both the door and frame header. Ensure that the door opens away from the Maglock. In the case of a single door, the Maglock is positioned as close as possible to the vertical section of the door jamb.

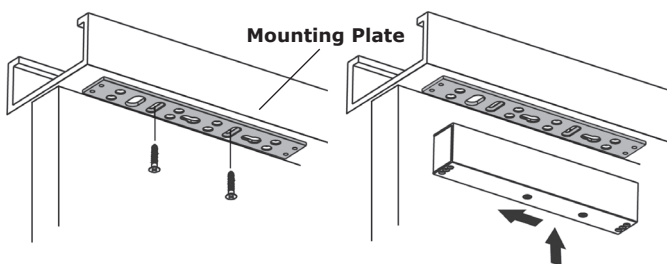
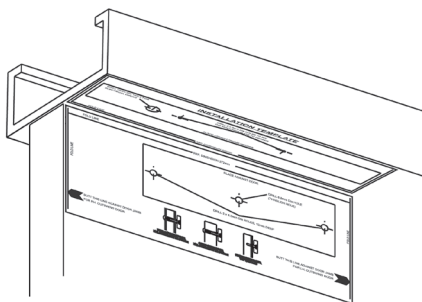

- Loosely install the mounting plate using two of the supplied philips head mounting screws in the elongated slots. Attach the Maglock to the mounting plate.

- Align the armature plate on the door using sight or the template supplied.
- Mark and drill holes then mount the armature to the door. Make sure that the armature plate is not over tightened and that it is installed as shown in the following diagram. The armature plate must be free to self align with the door.

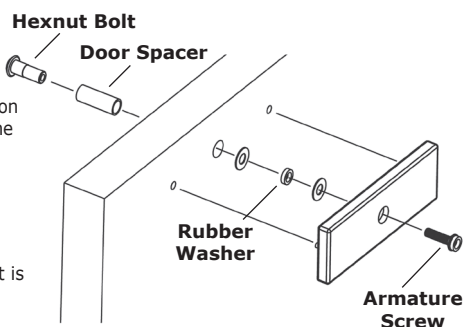

MOUNTING ARMATURE ON DIFFERENT DOOR TYPES

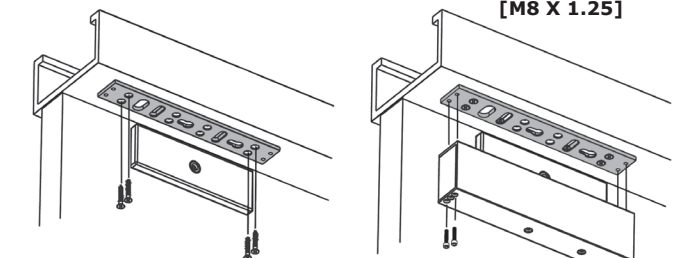
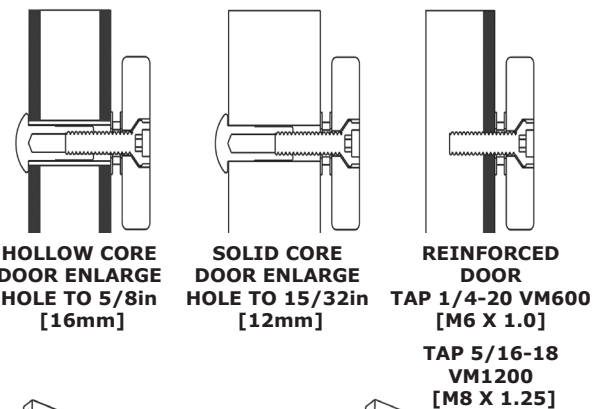

- Ensure the armature and magnet are aligned. Adjust the mounting plate to suit and then drill the appropriate sized holes in the door header for the remaining attachment screws.

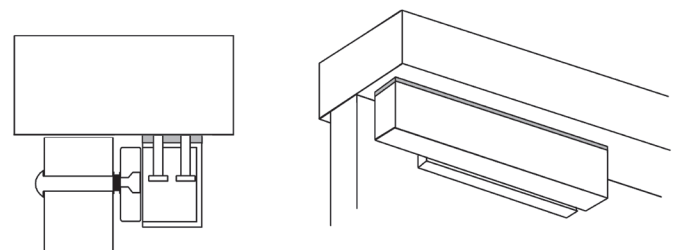

ADJUST POSITION OF MAGNET RELATIVE TO THE ARMATURE

6

MOUNTING THE ARMATURE

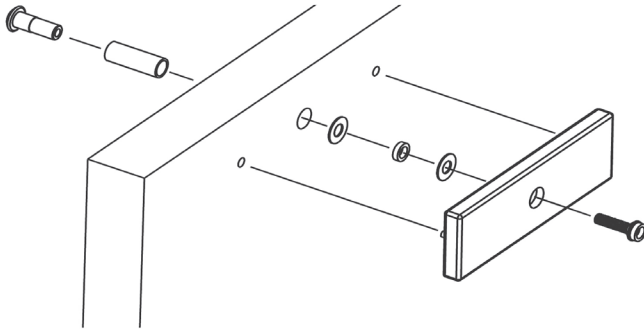

- Align the armature plate on the door using sight or the template supplied.
- Mark and drill holes then mount the armature to the door. Make sure that the armature plate is not over tightened and that it is installed as shown in the following diagram. The armature plate must be free to self align with the door.

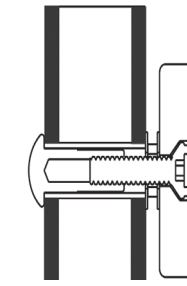

**HOLLOW CORE
DOOR ENLARGE
HOLE TO 5/8in
[16mm]**

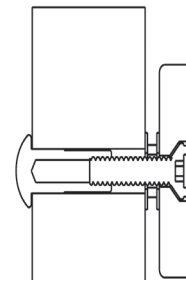

**SOLID CORE
DOOR ENLARGE
HOLE TO 15/32in
[12mm]**

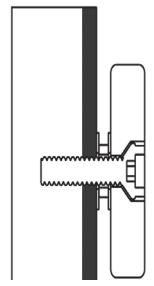

**REINFORCED
DOOR
TAP 1/4-20 VM600
[M6 X 1.25"]**

**MOUNTING ARMATURE
ON DIFFERENT DOOR TYPES**

**TAP 5/16-18 VM1200
[M8 X 1.25]**

7

MOUNTING THE MAGLOCK

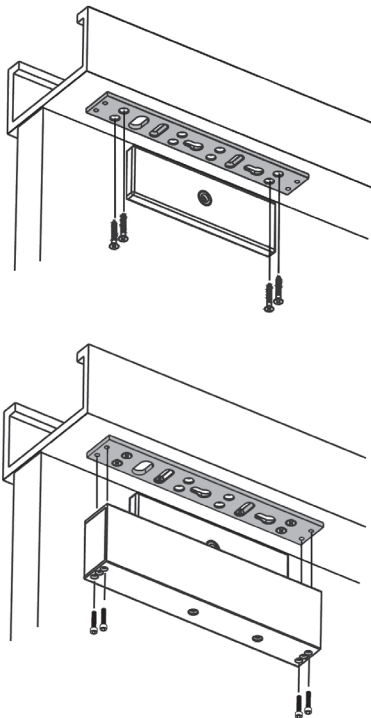

**Adjust position of
Magnet relative to
the Armature as shown**

- Ensure the armature and magnet are aligned. Adjust the mounting plate to suit and then drill the appropriate sized holes in the door header for the remaining attachment screws.

MOUNTING WITH Z BRACKET KITS

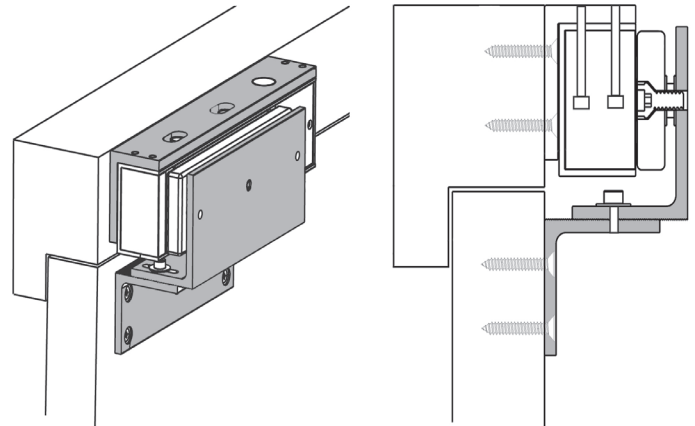

Assemble Z Bracket kit as shown

**Assemble Glass Door
Brackets as shown**

MOUNTING ON GLASS DOORS

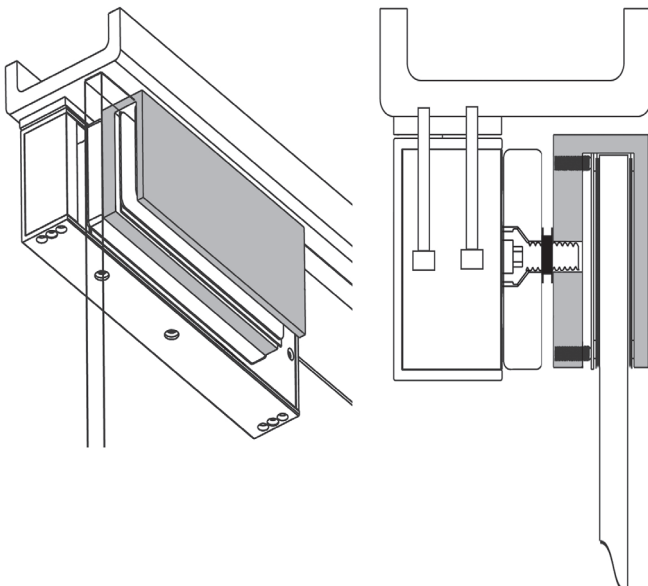

ELECTRICAL CONNECTION

Connect electrical wiring according to the local appropriate wiring rules. Make sure the correct voltage on the PCB has been selected prior to turning on the power. Failure to do this could damage the unit. Factory default voltage is set to 12volts DC.

Note: If a door closer has been fitted then adjust it so that the armature closes lightly against the magnet. This will avoid damage to the magnet and will also make the door operation quieter.

MAINTENANCE

The Maglock lock does not require much ongoing maintenance. The customer should be advised to keep the mating faces of the armature and magnet clean making sure that no abrasive materials are used to clean the faces.

Do not spray the magnet or armature with any chemicals such as lacquer as the release of the Maglock may be compromised.

**For complete Vista Maglock
Warranty information, please visit
www.securitron.com/vista.**

